

Restricted earth fault protection using an I_0 input of VAMP relay

Protection relays: VAMP 40, VAMP 50, VAMP 51, VAMP 52, VAMP 140, VAMP 150, VAMP 210, VAMP 230, VAMP245, VAMP 255, VAMP 265

1. Restricted earth fault protection

Restricted earth fault (REF) protection is a sensitive way to protect a zone between two measuring points against earth faults. See figure 1.

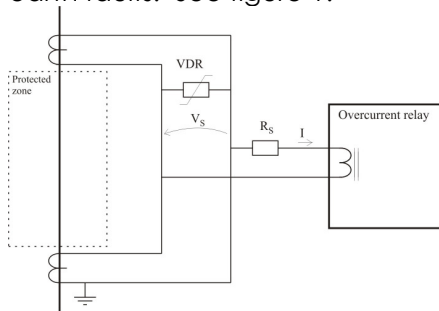

Figure 1. Principle of restricted earth fault protection. The CT secondaries are wired to cancel each other's currents during through faults and to drive all secondary current to the relay when the fault is inside the protected zone. (Saturation of the CTs makes the situation a little more complicated than that.) The stabilizing resistor R_s guarantees that the relay will not trip during a through fault. The VDR is used to protect the CTs and the wiring by limiting the voltage V_s during heavy inside faults.

When there is a fault outside the protected zone the CT secondaries will cancel each other's currents. This is partly true even if both or only one of the CTs saturates, because the impedance of a saturated CT secondary will collapse to near zero. The non zero wiring impedance and CT impedance will however cause a

voltage V_s , but the stabilizing resistor R_s will prevent the relay from tripping. During an inside fault the secondary currents of the two CTs have no other way to go than through the relay. The relay will trip when the current $I = V_s/R_s$ exceeds the setting I_s of the relay. The voltage dependent resistor (VDR, varistor, METROSIL) is used to protect the CTs and wiring by limiting the voltage V_s during heavy inside faults. The resistance of the secondary wiring connecting the CTs together, should be as low as possible.

2. Restricted earth fault protection for a transformer with neutral connection

Figure 2 shows an example where three phase current CTs are connected parallel with each other and then in series with the CT in the neutral point. The phase CTs are used for overcurrent protection as well.

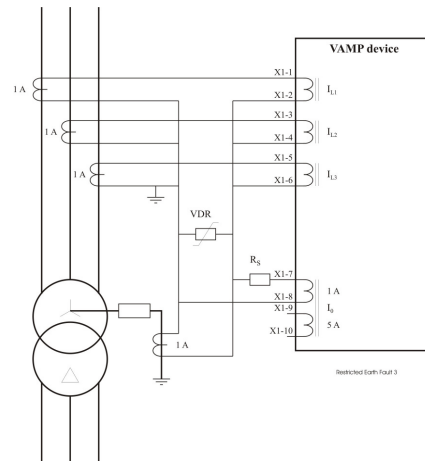

Figure 2. Restricted earth fault protection of a transformer's wye winding using VAMP 265 relay. All the CTs have the same ratio and the nominal secondary current is 1 A. During a through fault the residual secondary currents of phase CTs and the neutral CT cancel each other. During an inside fault the two residual secondary currents are summed up and

forced to flow through the relay and the voltage limiting VDR.

3. CT requirements

Any difference between the CTs will give a misleading residual current signal to the relay. Especially during heavy through faults (i.e. when the fault is outside the protected zone) the dissimilar saturation of the CTs should not yield to a REF trip. On the other hand a very high fault current causing an unselective earth fault start or trip is not a fatal error.

Class X CT

In restricted earth fault protection the high and low side CTs should give similar responses even for high over currents.

Class X CTs will fulfill this requirement. Their performance is defined in terms of a knee-point voltage (V_{KP}), the magnetizing current at the knee point voltage and the resistance of the secondary winding at +75 °C.

Knee point voltage (V_{KP}) is the secondary voltage at which a 50 % increase of primary current is needed to increase the secondary voltage by 10 %.

4. Calculating the stabilizing resistance R_s , VDR value and actual sensitivity

4.1 Value of stabilizing resistor R_s

The voltage V_s (Figure) is:

Equation 1

$$V_s = I_{MAXT} \frac{CT_{SEC}}{CT_{PRIM}} (R_{CT} + R_w)$$

- I_{MAXT} = Maximum through fault current not to cause an REF trip*
- CT_{SEC} = Nominal secondary current of the CT
- CT_{PRI} = Nominal primary current of the CT
- R_{CT} = Resistance of CT secondary.
- R_w = Total resistance of wiring, connections etc.

The CT should be of class X (see **CT requirements**) and the knee point voltage should be twice the calculated V_s .

The stabilizing resistor R_s is calculated as:

Equation 2

$$R_s = \frac{V_s}{I_{Set}}$$

I_{Set} = Setting value of the relay as secondary value.

*Selecting a low value helps to achieve more sensitivity and helps to avoid the usage of a voltage limiting VDR. An unselective earth fault pick-up/trip is not always a problem if a fast overcurrent stage will clear the fault anyway.

4.2 Voltage limitation

During heavy inside faults the voltage in the secondary circuit may rise to several kilovolts depending on the fault currents, CT properties and the stabilizing resistor R_s . If the secondary voltage would exceed 2 kV it should be limited using a voltage dependent resistor (VDR).

The peak voltage according a linear CT model is:

Equation 3

$$V_p = I_{MAXF} \frac{CT_{SEC}}{CT_{PRIM}} (R_{CT} + R_w + R_s)$$

- I_{MAXF} = Maximum fault current when the fault is inside the protected zone
- CT_{SEC} = Nominal secondary current of the CT
- CT_{PRI} = Nominal primary current of the CT
- R_{CT} = Resistance of CT secondary.
- R_w = Total resistance of wiring, connections, relay input etc.
- R_s = Stabilizing resistor according equation 2.

The peak voltage of a saturating CT can be approximated using P. Mathews' formulae (Ref. 1):

Equation 4

$$V_{sp} = 2\sqrt{2V_{KP}(V_P - V_{KP})}$$

V_{KP} = Knee point voltage of the CT. The secondary voltage at which a 50 % increase of primary current is needed to increase the secondary voltage by 10 %.

V_P = Peak voltage according linear model of a CT

This approximating formulae does not hold for an open circuit condition and is inaccurate for very high burden resistances. (Ref. 2)

4.3 Actual operating sensitivity

The differential scheme will multiply the fault current by two thus increasing the sensitivity from the actual setting. The quiescent current of the possible VDR will decrease the sensitivity from the actual setting value.

4.4 Example

CT = 2000/1 $V_{KP} = 100$ V
 $I_{MAXT} = 16$ kA = $8 \times I_N$
 $I_{REF} = 5\%$ = 50 mA Setting value scaled to secondary level
 $R_{CT} = 6$ Ω
 $R_W = 0.4$ Ω
 $I_{MAXF} = 25$ kA

Maximum secondary voltage during a through fault (Equation 1):

$$V_s = 16000 \frac{1}{2000} 6 + 0.4 - 51.2 \text{ V}$$

Conclusion: The knee point voltage of 100 V is acceptable being about twice the V_s .

Serial resistance for the relay input (Equation 2):

$$R_s = \frac{51.2}{0.05} = 1024 \text{ } \Omega \approx 1000 \text{ } \Omega$$

Maximum peak voltage during inside fault using a linear model for CT (Equation 3):

$$V_p = 25000 \frac{1}{2000} (6 + 0.4 + 1000) = 12.6 \text{ kV}$$

Approximation of peak voltage during inside fault using a non-linear model for a saturating CT (Equation 4):

$$V_{sp} = 2\sqrt{2 \cdot 100(12600 - 100)} = 3.2 \text{ kV}$$

This is a too high value and a VDR must be used to reduce the voltage below 3 kV.

A zinc oxide varistor (i.e. VDR, METROSIL) of 1 kV will limit the voltage. Using a 400 J model allows two 20 VA CTs feeding ten times their nominal power during one second before the energy capacity of the varistor is exceeded.

References:

Ref. 1 IEE: Power system protection, Volume 3, Application. Chapter 13.5.6 (Electricity Association Services Limited 1995. ISBN 0 85296 837 X)

Original source:

P. Mathews: Protective current transformers and circuits (Chapman & Hall 1955)

Ref. 2 GEC Alstom: Protective relays, Application guide. Chapter 15.7.6. (GEC Alstom measurements limited, 1987)

VAMP Ltd Visiting Address: Tel: +358 20 753 3200
P.O.Box 810 Vaasa Airport Park Fax: +358 20 753 3205
FI-65101 VAASA Yrittäjänkatu 15 Email: vamp@vamp.fi
Finland Vaasa, Finland http://www.vamp.fi

We reserve the rights to product alterations without prior notice.
Copyright © Vamp Ltd. All trademarks are the property of their respective holders.



ISO 9001:2000
certified company

