

Dual port 100Mbps Ethernet interface in VAMP 2xx and VAMP 5x relay series

Features

Compared to the former single port Ethernet interface, the built-in dual port Ethernet interface offers several new features:

- ability to operate at 100Base-Tx or 10Base-T (with conformance to the auto negotiation protocol as described by 802.3 committee)
- integrated Layer-2 switch compliant with IEEE 802.3u standard
- port mirroring / sniffing support
- broadcast storm protection logic
- HP Auto-MDIX crossover logic to eliminate the need for crossover cables between similar devices

Hardware options

There are two hardware options for dual port Ethernet interface:

- Interface with two RJ-45 ports

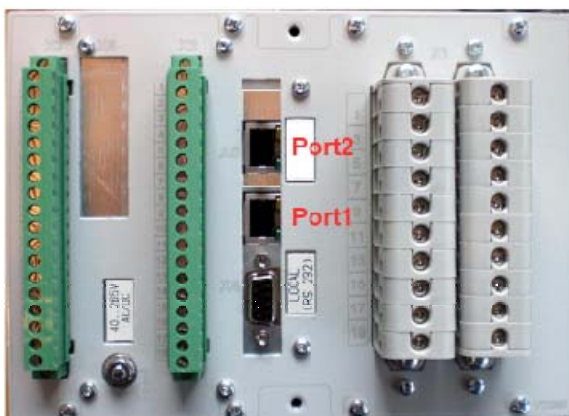

VAMP 2xx series



VAMP 5x series

- Interface with two fiber optic ports

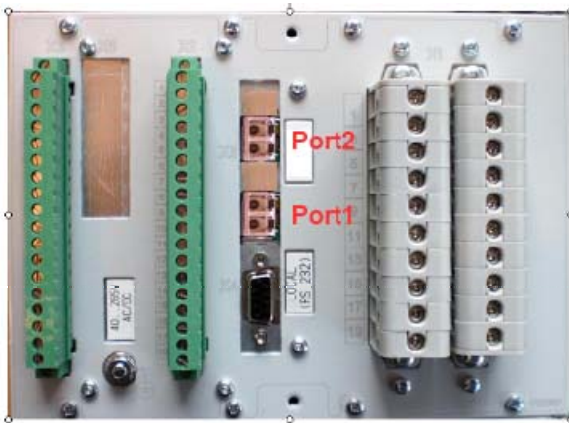

VAMP 2xx series



VAMP 5x series

NOTE: The auxiliary power supply for VAMP 50-series must be $\geq 110V$, when the option with two fiber optic ports is used.

Integrated Layer-2 switch

The presence of an integrated Layer-2 switch compliant with IEEE 802.3u standard eliminates the need of using stand-alone network switches within a small network of VAMP relays. Instead of widely used star topology, chain topology can be used with several devices connected in series, as shown below.

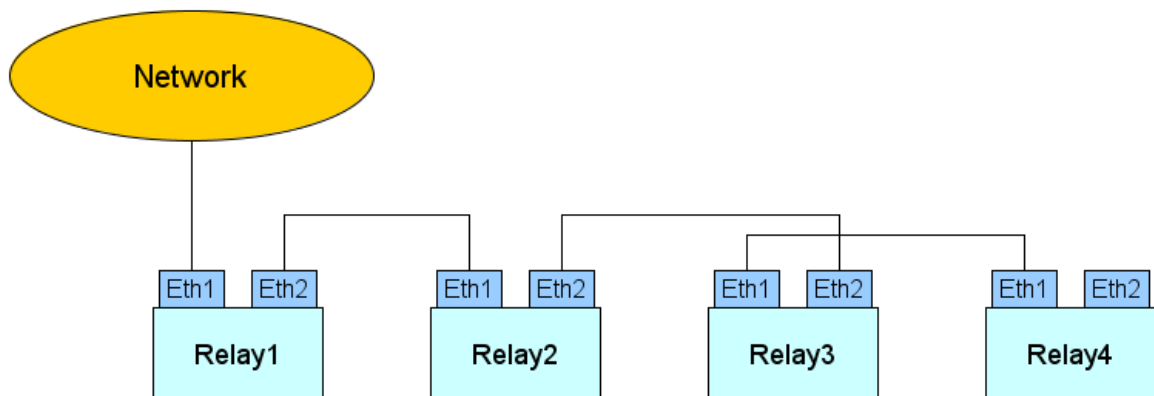

Chain topology can be a cost effective solution for networks that are not supposed to be failure resistant in terms of network connectivity.

Remember that this configuration has some drawbacks:

- increased delay for the last device in the chain,
- increased network traffic through the first device in the chain,
- single cable damage can isolate more than one device depending on the place in the chain where the damage occurs (in the worst case all devices could be disconnected from the network).

Port sniffing support

With the new Ethernet interface it is possible to monitor all packets received and transmitted by VAMP relay. This so called Sniffer mode can be enabled under ETHERNET PORT group on PROTOCOL CONFIGURATION tab in Vampset. Sniffer port is always set to EthPort2 and cannot be changed, thus an external device used for network traffic monitoring should be connected to Port2.

ETHERNET PORT	
Ethernet port protocol	IEC-61850
IP port for protocol	102
IP Address	10.4.128.19
NetMask	255.255.255.0
Gateway	0.0.0.0
NTP server	0.0.0.0
IP port for setting tool	23
TCP keepalive interval	0 s
MAC address	000102030405
Message counter	0
Error counter	0
Timeout counter	0
Sniffer Mode	<input type="checkbox"/>
Sniffer Port	EthPort2
Storm protection limit	20.0 %
Storm protection on Port1	<input type="checkbox"/>
Storm protection on Port2	<input type="checkbox"/>

Remember that Sniffer mode cannot be enabled if Storm protection logic is already enabled on at least one port.

Broadcast storm protection logic

Dual port Ethernet interface with an integrated switch includes a function protecting the switch system from receiving too many broadcast packets. As the broadcast packets are forwarded to all ports except the source port, an excessive number of switch resources (bandwidth and available space in transmit queues) may be utilized. It can lead to performance degradation within a network. To prevent such situations, the storm protection logic can be enabled separately for each port under ETHERNET PORT group on PROTOCOL CONFIGURATION tab in Vampset. Storm protection limit parameter can be used to adjust how many broadcast packets should be forwarded. This setting is common for both ports.

ETHERNET PORT	
Ethernet port protocol	IEC-61850
IP port for protocol	102
IP Address	10.4.128.19
NetMask	255.255.255.0
Gateway	0.0.0.0
NTP server	0.0.0.0
IP port for setting tool	23
TCP keepalive interval	0 s
MAC address	000102030405
Message counter	0
Error counter	0
Timeout counter	0
Sniffer Mode	<input type="checkbox"/>
Sniffer Port	EthPort2
Storm protection limit	20.0 %
Storm protection on Port1	<input type="checkbox"/>
Storm protection on Port2	<input type="checkbox"/>

Remember that Storm protection logic cannot be enabled on any port if Sniffer mode is already enabled.

Parameters

The number and type of available Ethernet ports in the present HW configuration can be checked by reading the following parameters in Vampset terminal window:

g ethports (availability of ethernet ports)

The possible values are: EthPort1 (default), EthPort2, EthPorts12.

g ethhw (type of ethernet controller)

The possible values are: LAN91C96, KSZ8842, No, Lost.

g EthP1Fibre and g EthP2Fibre (type of physical connection)

The possible values are On and Off.

VAMP Ltd
P.O.Box 810
FI-65101 VAASA
Finland

Visiting Address:
Vaasa Airport Park
Yrittäjänkatu 15
Vaasa, Finland

Tel: +358 20 753 3200
Fax: +358 20 753 3205
Email: vamp@vamp.fi
<http://www.vamp.fi>



ISO 9001:2000
certified company



We reserve the rights to product alterations without prior notice.
Copyright © Vamp Ltd. All trademarks are the property of their respective holders.