

### Intermittent transient earth fault protection

The directional intermittent transient earth fault protection is used to detect short intermittent transient faults in compensated cable networks (figure 1). The transient faults are self-extinguishing at a zero crossing of the transient part of the fault current  $I_{Fault}$  and the fault duration is typically only 0.1 ms ... 1 ms.

Such faults may be caused by old cables with degraded water tightness. The earth fault resistance of cable earth faults are typically only a few ohms and the amplitude of the measured residual fault current spikes are high – up to several hundred amperes. Figure 2 shows a typical transient earth fault current pulse measured at the feeding substation ( $I_{OFF}$ ).

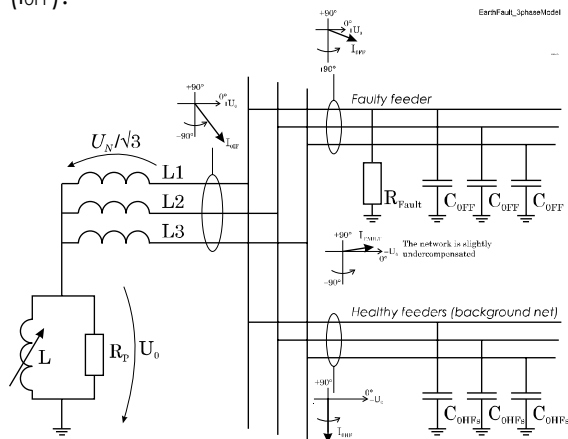

Figure 1. Compensated network

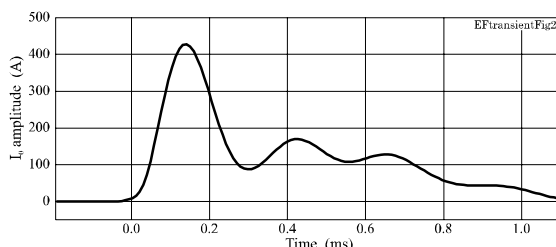

Figure 2. A typical transient earth fault current pulse

Although a single transient fault usually self-extinguishes within less than one millisecond, in most cases a new fault occurs when the phase-to-earth voltage of the faulty phase has recovered (figure 3). While recovery in a fully compensated network may take hundreds of milliseconds or more (figure 4), in under-compensated networks (figure 5) or overcompensated networks (figure 6) the next fault may already occur within the same or the next half cycle. Such short intermittent faults cannot be correctly identified with the normal directional earth fault function using only the fundamental frequency components of  $I_0$  and  $U_0$ . Over a longer period, such repetitious transient faults can develop into steady earth faults that a normal directional earth fault function will eventually be able to detect.

However, in a compensated network a sufficiently repetitious transient fault will keep up a continuous residual voltage as in figures 5 and 6; this will eventually activate the  $U_0 >$  backup protection. Unless the faulty feeder with the transient fault has been detected and isolated, the incoming feeder of the substation will trip unselectively.

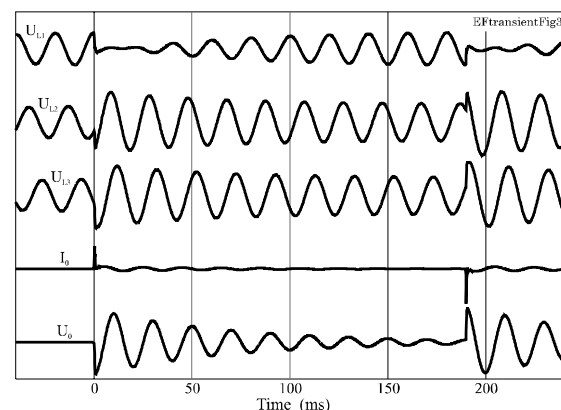

Figure 3. Typical phase to earth voltages, residual current of the faulty feeder and the zero sequence voltage  $U_0$  during two transient earth faults in phase L1. In this case the network is compensated.

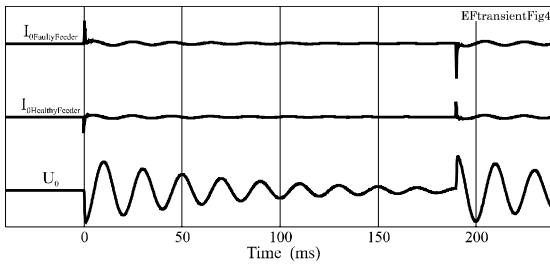

Figure 4. A typical residual current in the faulty feeder, one of the healthy feeders and the zero sequence voltage  $U_0$  during a transient earth fault in a fully compensated (100%) network.

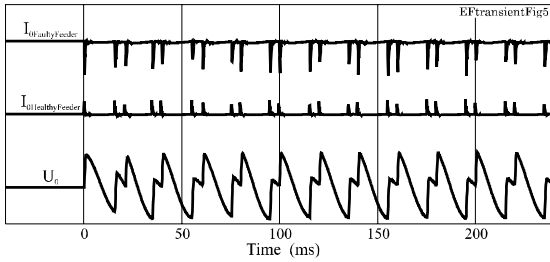

Figure 5. A typical residual current in the faulty feeder, one of the healthy feeders and the zero sequence voltage  $U_0$  during a transient earth fault in an under-compensated (30%) network.

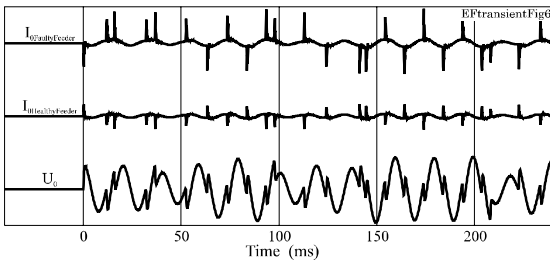

Figure 6. A typical residual current in the faulty feeder, one of the healthy feeders and the zero sequence voltage  $U_0$  during a transient earth fault in an over-compensated (170%) network.

## Direction algorithm

The function is sensitive to the instantaneous sampled values of the residual current and residual voltage. The selected voltage measurement mode has to include a direct  $-U_0$  measurement.

When both  $I_0$  peak value and the fundamental frequency value of  $U_0$  exceed their settings, the samples of both signals around the  $I_0$  peak are copied to a work buffer. If the  $I_0$  peak sample value exceeds the peak value of the calculated fundamental frequency component, the signals are

processed with a patent pending correlation algorithm, which indicates the direction of the fault.

## $I_0$ pick-up sensitivity

The sampling time interval of the relay is  $625 \mu\text{s}$  at 50 Hz (32 samples/cycle). The  $I_0$  current spikes can be quite short compared with this sampling interval. Fortunately the current spikes in cable networks are high and while the antialias filter of the relay is attenuating the amplitude the filter also makes the pulses wider. Thus, when the current pulses are high enough, it is possible to detect pulses with a duration of less than twenty per cent of the sampling interval. Although the measured amplitude can be only a fraction of the actual peak amplitude, it does not disturb the direction detection because the algorithm is more sensitive to the sign and timing of the  $I_0$  transient than to the absolute amplitude of the transient.

## Co-ordination with $U_0 >$ back up protection

Especially in a fully compensated situation, as in figure 4, the residual voltage backup protection stage  $U_0 >$  for the bus may not release between consecutive faults and the  $U_0 >$  may eventually make an unselective trip if the intermittent transient stage  $I_{0T} >$  does not operate fast enough. The actual operation time of the  $I_{0T} >$  stage is very dependent on the behaviour of the fault and the intermittent time setting. To simplify the co-ordination between  $U_0 >$  and  $I_{0T} >$ , the start signal of the transient stage  $I_{0T} >$  in an outgoing feeder can be used to block the  $U_0 >$  backup protection.

## Co-ordination with the normal directional earth fault protection based on fundamental frequency signals

The intermittent transient earth fault protection stage  $I_{0T} >$  should always be used together with the normal directional earth fault protection stages

$I_{0\phi} >$ ,  $I_{0\phi} \gg$ . In the worst case, the transient stage  $I_{0T} >$  may detect the start of a steady earth fault in the wrong direction, but not trip because the peak value of a steady state sine wave  $I_0$  signal must also exceed the peak value of the corresponding base frequency component in order to make the  $I_{0T} >$  trip.

The operation time of the transient stage  $I_{0T} >$  should be lower than the settings of any directional earth fault stage to avoid any unnecessary trip from the  $I_{0\phi} >$ ,  $I_{0\phi} \gg$  stages. The start signal of the  $I_{0T} >$  stage can be also used to block  $I_{0\phi} >$ ,  $I_{0\phi} \gg$  stages of all parallel feeders.

### Auto reclosing

Usually the  $I_{0T} >$  stage itself is not used to initiate any AR. For transient faults, the AR will not help because the fault phenomena itself already includes repeated self-extinguishing.

### Intermittent time

Single transient faults makes the protection to pick up, but do not cause a trip if the time between two successive faults is enough long for the stage to release and to reset the operation time counting. However, when the faults do occur often enough, such irregular faults can be cleared using the intermittent timer feature. When a new fault happens within the set intermittent time, the operation delay counter is not cleared between adjacent faults and the stage will eventually trip. A single transient fault is enough to start the stage and increase the delay counter by 20 ms. For example, if the operating time is 140 ms and the time between two peaks does not exceed the intermittent time setting, then the seventh peak will cause a trip (figure 7).

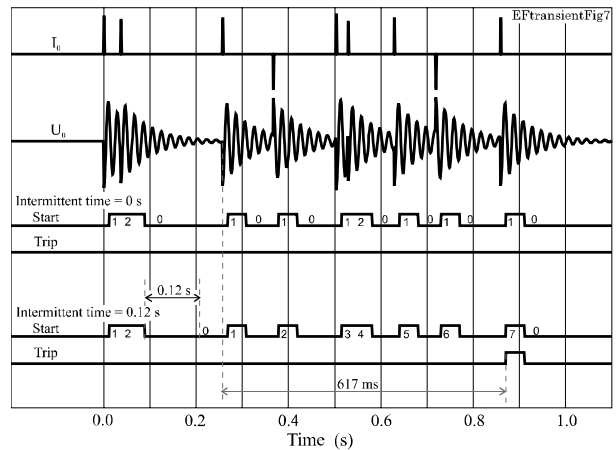

Figure 7. Effect of the intermittent time parameter. The operation delay setting is  $0.14 \text{ s} = 7 \times 20 \text{ ms}$ . The upper start and trip status lines are for a case with the intermittent time set at zero. No trip will occur. The lower start and trip status lines show another case with an intermittent time setting of  $0.12 \text{ s}$ . In this case a trip signal will be issued at  $t=0.87 \text{ s}$ .

### Operation time setting and the actual operation time

When the algorithm detects the direction of the fault outwards from the bus, the stage picks up and the operation delay counter is incremented with 20 ms, and a start signal is issued. If the time between successive faults is less than 40 ms, a trip signal is issued when the operation time is full. Figures 5 and 6 are examples of fault types that provide such straightforward operation delay counting.

When the time between successive faults is more than 40 ms (figure 4), the stage releases between the faults and the delay counting is restarted from zero for every single fault and no trip is issued. For such cases, the intermittent setting can be used. Figure 7 shows an example of how the intermittent setting works. The upper start and trip signals have an intermittent setting of zero. The lower signals are another case with an intermittent setting of  $0.12 \text{ s}$ . The operation time setting is  $0.14 \text{ s}$  in both cases, which corresponds to seven 20 ms time slots with faults.

The time between the second and the third fault exceeds the release time + intermittent time. Thus the operation delay counter is cleared in both cases:

with an intermittent time of zero and with an intermittent time of 0.12 s. The fourth and the next faults occur after the release time but within the release time + the intermittent time.

Thus the operation delay counter is advanced at every fault when the intermittent time setting is more than 100 ms (the start status lines in the figure 7) and a trip signal is eventually issued at  $t=0.87$  s.

When faults occur at intervals of more than 20 ms, every single fault will increment the operation delay counter by 20 ms. In this example the actual operation time starting from the third fault will be 617 ms although the setting was 140 ms. If the intermittent setting had been 0.2 s or more, the first two faults would have been included and a trip would have been issued at  $t=0.64$  s.

The intermittent transient earth fault protection is available in Vamp 40, 245, 230, 255, 257 and 259 units having a firmware greater than v.6.28.

VAMP Ltd	Visiting Address:	Tel: +358 20 753 3200
P.O.Box 810	Vaasa Airport Park	Fax: +358 20 753 3205
FI-65101 VAASA	Yrittäjänkatu 15	Email: <a href="mailto:vamp@vamp.fi">vamp@vamp.fi</a>
Finland	Vaasa, Finland	<a href="http://www.vamp.fi">http://www.vamp.fi</a>

We reserve the rights to product alterations without prior notice.  
Copyright © Vamp Ltd. All trademarks are the property of their respective holders.



ISO 9001:2000  
certified company

