

# WIMO 6CP10

Secondary substation measuring and monitoring unit

Operation and configuration instructions

Technical description





## Table of Contents

<b>1. General</b> .....	<b>4</b>
1.1. Unit features .....	4
1.2. Operating Safety .....	4
<b>2. User interface</b> .....	<b>5</b>
2.1. General .....	5
2.2. Front panel .....	5
2.2.1. Display .....	6
2.2.2. Keypad .....	7
2.2.3. Indicators .....	7
<b>3. Local panel operations</b> .....	<b>8</b>
3.1. Navigating in menus .....	8
3.2. Operating levels .....	10
3.2.1. Opening configuration level .....	10
3.2.2. Password handling .....	11
<b>4. Operating measures</b> .....	<b>12</b>
4.1. Default displays .....	12
4.2. Measured data .....	12
4.3. Operation indicators .....	17
4.4. Reading event register .....	18
4.5. Adjusting display contrast .....	18
<b>5. Configuration and parameter setting</b> .....	<b>19</b>
5.1. Principle of parameter setting .....	20
5.2. Disturbance recorder menu DR .....	21
5.3. Configuring digital inputs DI .....	22
5.4. Configuring digital output .....	22
5.5. Configuration menu CONF .....	22
5.6. Protocol menu Bus .....	23
<b>6. PC software</b> .....	<b>26</b>
6.1. PC user interface .....	26
6.1.1. Using VAMPSET program .....	26
6.2. Remote control connection .....	26
<b>7. Commissioning configuration</b> .....	<b>27</b>
7.1. Factory settings .....	27
7.1.1. Configuration during commissioning .....	27

# 1. General

This part of the manual describes the functions of the secondary substation measuring and monitoring unit WIMO 6CP10 and includes the unit operation instructions. It also contains instructions for parameterization and configuration of the unit and instructions for changing settings.

The second part of the publication includes detailed protection function descriptions as well as application examples, accessories and technical data sheets.

## 1.1. Unit features

WIMO 6CP10 secondary substation measuring and monitoring unit is a compact multi-function monitoring device with extensive measuring and calculation functions. Setting and programming possibilities are comprehensive and versatile. WIMO 6CP10 is ideal for secondary substation measuring and monitoring management.

The unit measures currents, voltages and frequencies and calculates following values:

- Active, reactive and apparent power
- Active and reactive energy
- Harmonics and THD of currents and voltages
- Programmable average value calculations
- One change over relay output

Further, the unit includes 3 configurable digital channels.

WIMO 6CP10 communicates with other systems using common protocols, such as the Modbus RTU, ModbusTCP, Profibus DP, IEC 60870-5-103 SPA bus, DNP 3.0.

## 1.2. Operating Safety



The terminals on the rear panel of the unit may carry dangerous voltages, even if the auxiliary voltage is switched off. A live current transformer secondary circuit must not be opened.

**Disconnecting a live circuit may cause dangerous voltages!** Any operational measures must be carried out according to national and local handling directives and instructions.

Carefully read through all operation instructions before any operational measures are carried out.

## 2. User interface

### 2.1. General

WIMO 6CP10 secondary substation measuring and monitoring unit can be controlled in three ways:

- Locally with the push-buttons on the device front panel
- Locally using a PC connected to the serial port on the front panel or on the rear panel of the device (both cannot be used simultaneously)
- Via remote control over the remote control port on the unit rear panel.

### 2.2. Front panel

The figure below shows the front panel of the unit and the location of the user interface elements used for local control.

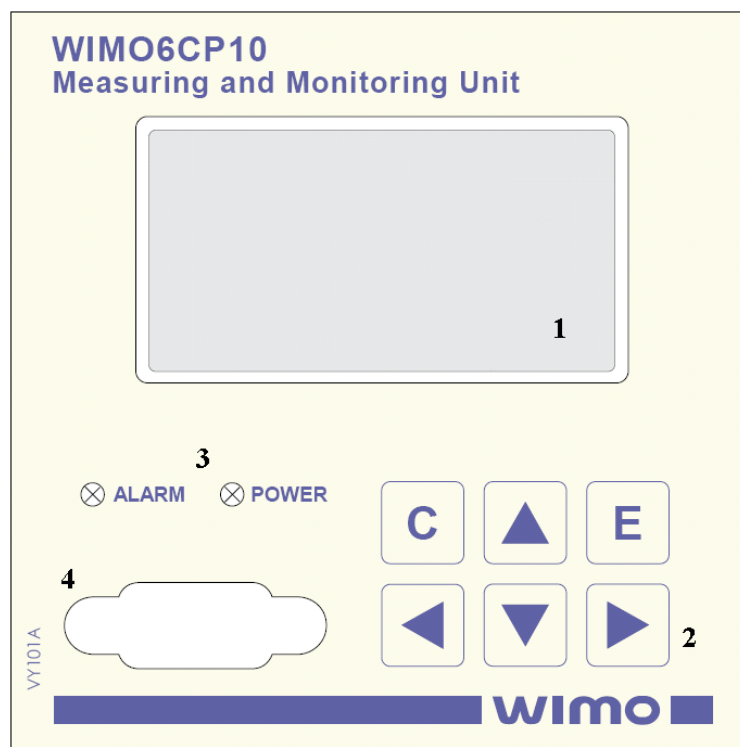
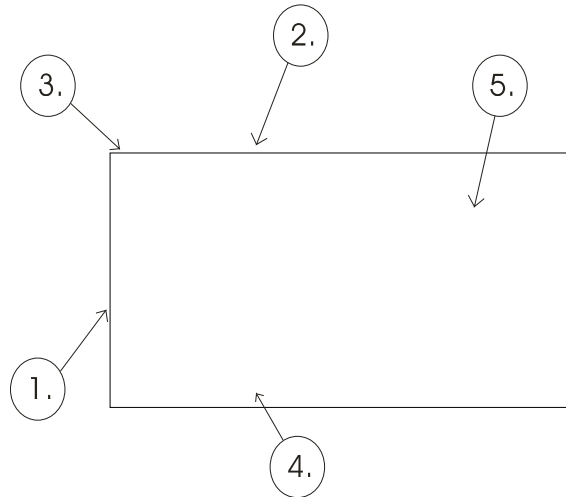

Figure 2.2-1. WIMO 6CP10 front panel

1. LCD dot matrix display
2. Keypad
3. LED indicators
4. RS 232 serial communication port for PC

## 2.2.1. Display

WIMO 6CP10 is provided with a backlit LCD dot matrix display. The display has 128 x 64 dots, which enables showing 21 characters in one row and eight rows at the same time. The display is divided into sections as shown in the next figure



*Figure 2.2.1-1 Sections of the LCD dot matrix display*

1. Main menu column
2. Heading of active menu
3. Possible navigating directions (push buttons)
4. Measured/adjustable quantity
5. Measured/set value

## 2.2.2. Keypad

You can navigate in the menu and set the required parameter values using the keypad and the guidance given in the display. The key pad is composed of four arrow keys, one cancel key and one enter key.

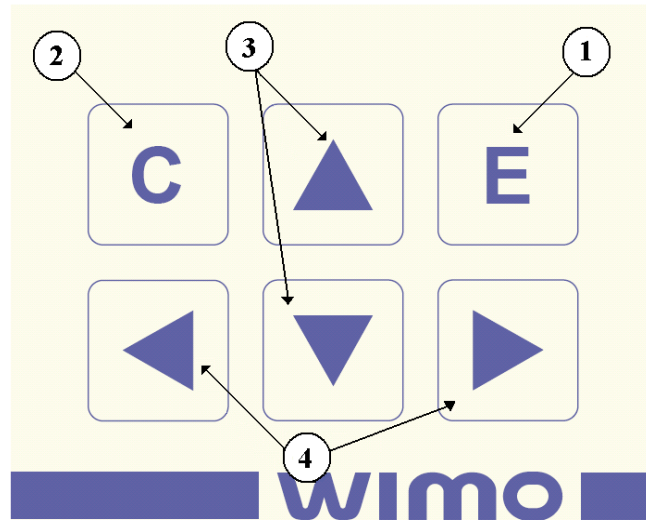

Figure 2.2.2-1 Keys on the keypad

1. Enter and confirmation key (ENTER)
2. Cancel key (CANCEL)
3. Up/Down [Increase/Decrease] arrow keys (UP/DOWN)
4. Keys for selecting submenus [selecting a digit in a numerical value] (LEFT/RIGHT)

### NOTE!

The term, which is used for the buttons in this manual, is inside the brackets.

## 2.2.3. Indicators

The unit is provided with two LED indicators:

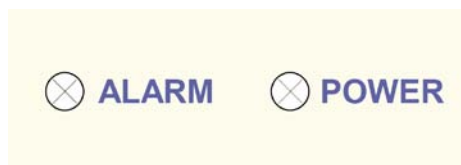

Figure 2.2.3-1. Operation indicators of the unit

- Power** Auxiliary voltage switched on  
**Alarm** Programmable alarm indicator

## 3. Local panel operations

The local panel is being used to read measured values, to set parameters and to configure unit functions. Some parameters, however, can only be set by means of a PC connected to one of the local communication ports. Further some parameters are factory set.

### 3.1. Navigating in menus

All the menu functions are based on the main menu/submenu structure:

1. Use the arrow keys UP and DOWN to move up and down in the main menu.
2. For moving to a submenu, repeatedly push the RIGHT key until the required submenu is shown. Correspondingly, push the LEFT key to return to the main menu.
3. Push the ENTER key to confirm the selected submenu.
4. Push the CANCEL key to cancel a selection.
5. Pushing the UP or DOWN key in any position of a submenu, when it is not selected, brings you directly one step up or down in the main menu.

The active main menu selection is indicated with black background color. The possible navigating directions in the menu are shown in the upper-left corner by means of black triangular symbols.

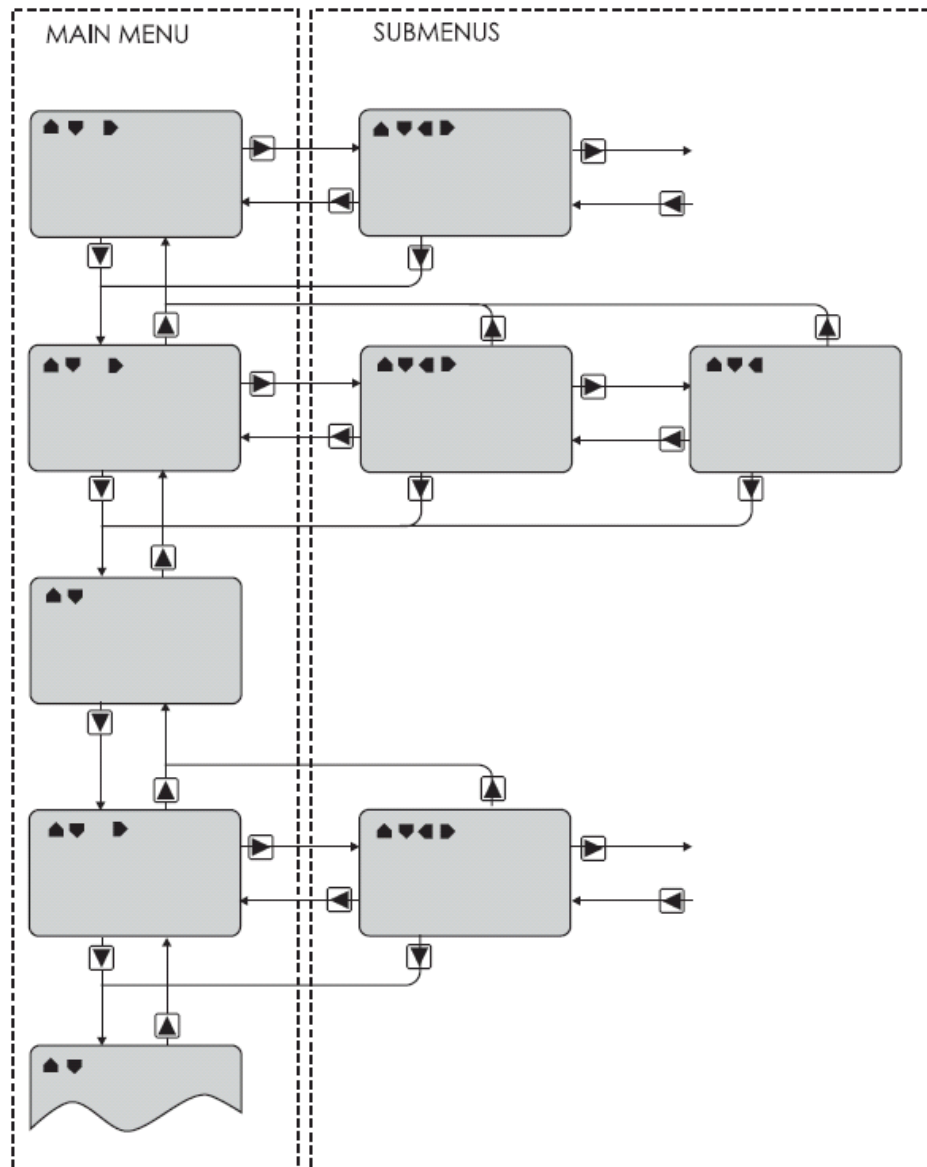

Figure 3.1-1. Principles of the menu structure and navigation in the menus

6. Push the INFO key to obtain additional information about any menu item.
7. Push the CANCEL key to revert to the normal display.

## 3.2. Operating levels

The unit has two operating levels: *User level* and *Configuration level*. The purpose of the configuration level is to prevent accidental change of unit configurations, parameters or settings.

### USER level

Use:	Possible to read e.g. parameter values, measurements and events
Opening:	Level permanently open
Closing:	Closing not possible

### CONFIGURATION level

Use:	The configuration level is needed during the commissioning of the unit. E.g. the scaling of the voltage and current transformers can be set.
Opening:	Default password 0002
Setting state:	Push ENTER
Closing:	The level is automatically closed after 10 minutes idle time. Giving the password 9999 can also close the level.

### 3.2.1. Opening configuration level

1. Push the LEFT key and the RIGHT key on the front panel simultaneously.

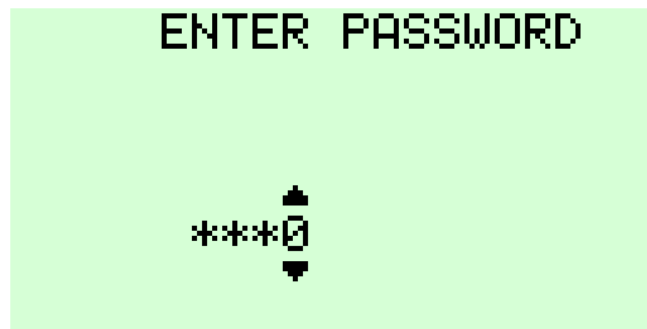

Figure 3.2.1-1. Opening the operating level

2. Enter the password needed for the desired level: the password can contain four digits. The digits are supplied one by one by first moving to the position of the digit using the RIGHT key and then setting the desired digit value using the UP key.
3. Push the ENTER key.

### 3.2.2. Password handling

The passwords can only be changed using VAMPSET software connected to the local RS-232 port on the unit.

It is possible to restore the password(s) in case the password is lost or forgotten. In order to restore the password(s), VAMPSET software is needed. The serial port settings are 38400 bps, 8 data bits, no parity and one stop bit. The bit rate is configurable via the front panel.

Command	Description
get pwd_break	Get the break code (Example: 6569403)
get serno	Get the serial number of the unit (Example: 12345)

Send both numbers to [vampsupport@vamp.fi](mailto:vampsupport@vamp.fi). A device specific break code is sent back to you. The break code will be valid for the next two weeks.

Command	Description
set pwd_break=4435876	Break the passwords (The number "4435876" is sent by VAMP Ltd.)

Now the passwords are restored to the default values (See chapter 3.2).

## 4. Operating measures

Study carefully the operating instructions presented in chapters 1 to 3 in this manual before taking any operating measures or changing any unit settings or functions.

WIMO 6CP10 can be controlled via the unit front panel, a PC running the VAMPSET software, a PC running suitable unit software or via a remote control system.

### 4.1. Default displays

WIMO 6CP10 has 5 default displays.

Display 1/5 contains IL1, IL2, IL3 and Io.

Display 2/5 contains U12, U23, U31 and Uo.

Display 3/5 contains UL1, UL2, UL3 and Uo.

Display 4/5 contains f, P, Q and S.

Display 5/5 contains PF and CosPhi.

You can change these default values VIA vampset software. See the chapter 7.1.1.

### 4.2. Measured data

The measured values can be read from the P, E, I and U menus and their submenus. Some of these values can also be seen in default displays 1-5.

Value	Menu/Submenu	Description
P	P/POWER	Active power [kW]
Q	P/POWER	Reactive power [kvar]
S	P/POWER	Apparent power [kVA]
$\varphi$	P/POWER	Active power angle [°]
P.F.	P/POWER	Power factor [ ]
f	P/POWER	Frequency [Hz]
Prms	P/RMS POWER	RMS of active power
Qrms	P/RMS POWER	RMS of reactive power
Srms	P/RMS POWER	RMS of apparent power
Diagram	P/PQ DIAGRAM	Active and reactive power diagram
Pda	P/POWER DEAMAND	Active power demand value
Qda	P/POWER DEAMAND	Reactive power demand value
Sda	P/POWER DEAMAND	Apparent power demand value
PFda	P/POWER DEAMAND	Power factor demand value
fda	P/POWER DEAMAND	Frequency demand value
Prmsda	RMS POWER DEMAND	Active power RMS demand value
Qrmsda	RMS POWER DEMAND	Reactive power RMS demand value

Value	Menu/Submenu	Description
Srmsda	RMS POWER DEMAND	Apparent power RMS demand value
PL1	P/POWER/PHASE 1	Active power of phase 1 [kW]
PL2	P/POWER/PHASE 1	Active power of phase 2 [kW]
PL3	P/POWER/PHASE 1	Active power of phase 3 [kW]
QL1	P/POWER/PHASE 1	Reactive power of phase 1 [kvar]
QL2	P/POWER/PHASE 1	Reactive power of phase 2 [kvar]
QL3	P/POWER/PHASE 1	Reactive power of phase 3 [kvar]
SL1	P/POWER/PHASE 2	Apparent power of phase 1 [kVA]
SL2	P/POWER/PHASE 2	Apparent power of phase 2 [kVA]
SL3	P/POWER/PHASE 2	Apparent power of phase 3 [kVA]
PF_L1	P/POWER/PHASE 2	Power factor of phase 1 [ ]
PF_L2	P/POWER/PHASE 2	Power factor of phase 2 [ ]
PF_L3	P/POWER/PHASE 2	Power factor of phase 3 [ ]
Cos	P/COS & TAN	Cosine phi [ ]
tan	P/COS & TAN	Tangent phi [ ]
cosL1	P/COS & TAN	Cosine phi of phase L1 [ ]
cosL2	P/COS & TAN	Cosine phi of phase L2 [ ]
cosL3	P/COS & TAN	Cosine phi of phase L3 [ ]
Iseq	P/PHASE SEQUENCIES	Actual current phase sequency [OK; Reverse; ??]
Useq	P/PHASE SEQUENCIES	Actual voltage phase sequency [OK; Reverse; ??]
Io	P/PHASE SEQUENCIES	Io angle [°]
fAdop	P/PHASE SEQUENCIES	Adopted frequency [Hz]
PDir	P/PHASE SEQUENCIES	Power direction
Diagram	P/PL1 DIAGRAM	Diagram of active power PL1
Diagram	P/PL2 DIAGRAM	Diagram of active power PL2
Diagram	P/PL3 DIAGRAM	Diagram of active power PL3
Diagram	P/ ACTIVE POWER TREND	Trend of active power
Diagram	P/ REACTIVE POWER TREND	Trend of reactive power
Diagram	P/ APPARENT POWER TREND	Trend of apparent power
E+	E/ENERGY	Exported energy [MWh]
Eq+	E/ENERGY	Exported reactive energy [Mvar]
E-	E/ENERGY	Imported energy [MWh]
Eq-	E/ENERGY	Imported reactive energy [Mvar]
E+.nn	E/DECIMAL COUNT	Decimals of exported energy [ ]
Eq.nn	E/DECIMAL COUNT	Decimals of reactive energy [ ]
E-.nn	E/DECIMAL COUNT	Decimals of imported energy [ ]
Ewrap	E/DECIMAL COUNT	Energy control
E+	E/E-PULSE SIZES	Pulse size of exported energy [kWh]
Eq+	E/E-PULSE SIZES	Pulse size of exported reactive energy [kvar]

Value	Menu/Submenu	Description
E-	E/E-PULSE SIZES	Pulse size of imported energy [kWh]
Eq-	E/E-PULSE SIZES	Pulse duration of imported reactive energy [ms]
E+	E/E-PULSE DURATION	Pulse duration of exported energy [ms]
Eq+	E/E-PULSE DURATION	Pulse duration of exported reactive energy [ms]
E-	E/E-PULSE DURATION	Pulse duration of imported energy [ms]
Eq-	E/E-PULSE DURATION	Pulse duration of imported reactive energy [ms]
E+	E/Epulse TEST	You may give test pulse
Eq+	E/Epulse TEST	You may give test pulse
E-	E/Epulse TEST	You may give test pulse
Eq-	E/Epulse TEST	You may give test pulse
IL1	I/PHASE CURRENTS	Phase current IL1 [A]
IL2	I/PHASE CURRENTS	Phase current IL2 [A]
IL3	I/PHASE CURRENTS	Phase current IL3 [A]
IL1da	I/PHASE CURRENTS	15 min average for IL1 [A]
IL2da	I/PHASE CURRENTS	15 min average for IL2 [A]
IL3da	I/PHASE CURRENTS	15 min average for IL3 [A]
Angle diagram	I/ANGLE DIAGRAM	Angle of currents IL1-IL3
Io	I/SYMMETRIC CURRENTS	Primary value of zerosequence/residual current Io [A]
IoC	I/SYMMETRIC CURRENTS	Calculated Io [A]
I1	I/SYMMETRIC CURRENTS	Positive sequence current [A]
I2	I/SYMMETRIC CURRENTS	Negative sequence current [A]
I2/I1	I/SYMMETRIC CURRENTS	Negative sequence current related to positive sequence current (for unbalance protection) [%]
THDIL	I/HARM. DISTORTION	Total harmonic distortion of the mean value of phase currents [%]
THDIL1	I/HARM. DISTORTION	Total harmonic distortion of phase current IL1 [%]
THDIL2	I/HARM. DISTORTION	Total harmonic distortion of phase current IL2 [%]
THDIL3	I/HARM. DISTORTION	Total harmonic distortion of phase current IL3 [%]
Diagram	I/HARMONICS of IL1	Harmonics of phase current IL1 [%]
Diagram	I/HARMONICS of IL2	Harmonics of phase current IL2 [%]
Diagram	I/HARMONICS of IL3	Harmonics of phase current IL3 [%]
Diagram	I/IL1 WAVEFORM	Waveform of IL1

Value	Menu/Submenu	Description
Diagram	I/IL2 WAVEFORM	Waveform of IL2
Diagram	I/IL3 WAVEFORM	Waveform of IL3
Diagram	I/IL1 TREND	Trend of IL1
Diagram	I/IL2 TREND	Trend of IL2
Diagram	I/IL3 TREND	Trend of IL3
Uline	U/LINE VOLTAGES	Average value for the three line voltages [V]
U12	U/LINE VOLTAGES	Phase-to-phase voltage U12 [V]
U23	U/LINE VOLTAGES	Phase-to-phase voltage U23 [V]
U31	U/LINE VOLTAGES	Phase-to-phase voltage U31 [V]
UL	U(PHASE VOLTAGES	Average for the three phase voltages [V]
UL1	U/PHASE VOLTAGES	Phase-to-earth voltage UL1 [V]
UL2	U/PHASE VOLTAGES	Phase-to-earth voltage UL2 [V]
UL3	U/PHASE VOLTAGES	Phase-to-earth voltage UL3 [V]
Diagram	U/ ANGLE DIAGRAM 1	Diagram of line voltages
Diagram	U/ ANGLE DIAGRAM 2	Diagram of phase voltages
Uo	U/SYMMETRIC VOLTAGES	Uo value [%]
U1	U/SYMMETRIC VOLTAGES	Positive sequence voltage [%]
U2	U/SYMMETRIC VOLTAGES	Negative sequence voltage [%]
U2/U1	U/SYMMETRIC VOLTAGES	Negative sequence voltage related to positive sequence voltage [%]
THDU	U/HARM. DISTORTION	Total harmonic distortion of the mean value of voltages [%]
THDUa	U/HARM. DISTORTION	Total harmonic distortion of the voltage input a [%]
THDUb	U/HARM. DISTORTION	Total harmonic distortion of the voltage input b [%]
THDUc	U/HARM. DISTORTION	Total harmonic distortion of the voltage input c [%]
Diagram	U/HARMONICS of Ua	Harmonics of voltage input Ua [%]
Diagram	U/HARMONICS of Ub	Harmonics of voltage input Ub [%]
Diagram	U/HARMONICS of Uc	Harmonics of voltage input Uc [%]
Enable	U/VOLTAGE SAG & SWELL	On/off
Status	U/VOLTAGE SAG & SWELL	Voltage status
U<	U/VOLTAGE SAG & SWELL	Alarm level [%]
U>	U/VOLTAGE SAG & SWELL	Alarm level [%]
Delay	U/VOLTAGE SAG & SWELL	Delay in seconds [s]
LVBkck	U/VOLTAGE SAG & SWELL	Block level [%]
SagOn	U/VOLTAGE SAG & SWELL	Sag on event

Value	Menu/Submenu	Description
SagOff	U/VOLTAGE SAG & SWELL	Sag off event
SwelOn	U/VOLTAGE SAG & SWELL	Swell on event
SwelOf	U/VOLTAGE SAG & SWELL	Swell off event
Status	U/SAG & SWELL CNTRS	High
Count	U/SAG & SWELL CNTRS	Sag counter
Total	U/SAG & SWELL CNTRS	Total sag length in seconds
Count	U/SAG & SWELL CNTRS	Swell counter
Total	U/SAG & SWELL CNTRS	Total swell length in seconds
	U/SAG LOG	Date of sag [yyyy:mm:dd]
	U/SAG LOG	Time of sag [hh:mm:ss:ms]
Type	U/SAG LOG	Type of sag [Phases]
Duration	U/SAG LOG	Duration of sag [s]
Min1	U/SAG LOG	Minimum phase1 % of Un
Min2	U/SAG LOG	Minimum phase2 % of Un
Min3	U/SAG LOG	Minimum phase3 % of Un
Ave1	U/SAG LOG	Mean phase1 % of Un
Ave2	U/SAG LOG	Mean phase2 % of Un
Ave3	U/SAG LOG	Mean phase3 % of Un
Max1	U/SAG LOG	Maximum phase1 % of Un
Max2	U/SAG LOG	Maximum phase2 % of Un
Max3	U/SAG LOG	Maximum phase3 % of Un
	U/SWELL LOG	Date of swell [yyyy:mm:dd]
	U/SWELL LOG	Time of swell [hh:mm:ss:ms]
Type	U/SWELL LOG	Type of swell [Phases]
Duration	U/SWELL LOG	Duration of swell [s]
Max1	U/SWELL LOG	Maximum phase1 % of Un
Max2	U/SWELL LOG	Maximum phase2 % of Un
Max3	U/SWELL LOG	Maximum phase3 % of Un
Ave1	U/SWELL LOG	Mean phase1 % of Un
Ave2	U/SWELL LOG	Mean phase2 % of Un
Ave3	U/SWELL LOG	Mean phase3 % of Un
Min1	U/SWELL LOG	Minimum phase1 % of Un
Min2	U/SWELL LOG	Minimum phase2 % of Un
Min3	U/SWELL LOG	Minimum phase3 % of Un
Count	U/VOLT. INTERRUPTS	Voltage interrupts counter [ ]
Prev	U/VOLT. INTERRUPTS	Previous interruption [ ]
Total	U/VOLT. INTERRUPTS	Total duration of voltage interruptions [days, hours]
Prev	U/VOLT. INTERRUPTS	Duration of previous interruption [s]
Status	U/VOLT. INTERRUPTS	Voltage status [LOW; NORMAL]
U1	U/ VOLT INT SETTING	Current state of U1
U1<	U/ VOLT INT SETTING	Voltage interrupt limit [%]
Period	U/ VOLT INT SETTING	8h/day/week/month/year
Date	U/ VOLT INT SETTING	Year-month-day

Value	Menu/Submenu	Description
Time	U/ VOLT INT SETTING	Hours·minutes·seconds
Event	U/ VOLT INT SETTING	Enabled
I_On	U/ VOLT INT SETTING	Interrupt on event
I_Off	U/ VOLT INT SETTING	Interrupt off event

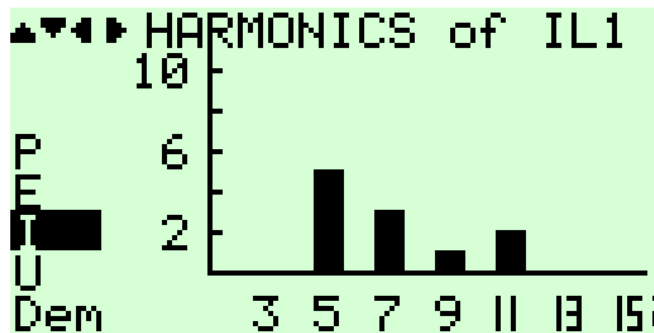

Figure 4.2-1. Example of harmonics bar display

### 4.3. Operation indicators

LED indicator	Meaning	Measure/ Remarks
Power LED lit	The auxiliary power has been switched on	Normal operation state
Alarm LED lit	One or several signals of the output relay matrix have been assigned to output A1 and the output has been activated by one of the signals.	The LED is switched off when the signal that caused output A1 to activate, e.g. the START signal, is reset. The resetting depends on the type of configuration, connected or latched.

#### Resetting latched alarm indicator

The alarm indicator can be given a latching function in the configuration.

There are several ways to reset latched alarm indicator:

- From the alarm list, move back to the initial display by pushing the CANCEL key for approx. 3 s. Then reset the latched alarm indicator by pushing the ENTER key.
- Acknowledge each event in the alarm list one by one by pushing the ENTER key equivalent times. Then, in the initial display, reset the latched alarm indicator by pushing the ENTER key.

The latched alarm indicator can also be reset via a remote communication bus or via a digital input configured for that purpose.

## 4.4. Reading event register

The event register can be read from the Evnt submenu:

1. Push the RIGHT key once.
2. The EVENT LIST appears. The display contains a list of all the events that have been configured to be included in the event register.

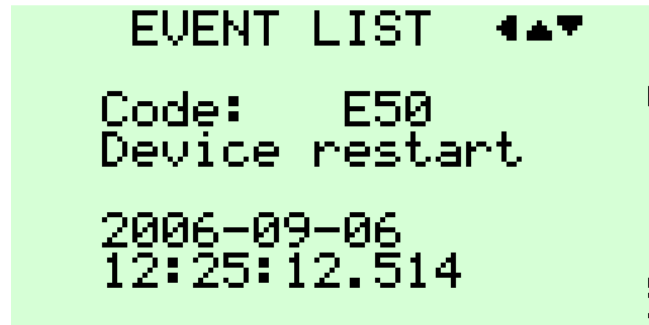

*Figure 4.4-1 Example of an event register*

3. Scroll through the event list with the UP and DOWN keys.
4. Exit the event list by pushing the LEFT key.

It is possible to set the order in which the events are sorted. If the “Order” -parameter is set to “New-Old”, then the first event in the EVENT LIST is the most recent event.

## 4.5. Adjusting display contrast

The readability of the LCD varies with the brightness and the temperature of the environment. The contrast of the display can be adjusted via the PC user interface.

Open VAMPSET software, proceed to the DEVICE INFO menu and set desired contrast value to the display contrast block.

More about VAMPSET in chapter 6 on page 26.

## 5. Configuration and parameter setting

### Operating level: CONFIGURATION

- Choose and configure the digital inputs in the DI submenu.
- Configure the NO relay output in the DO submenu.
- Set the "Device Setup", the scaling (for example Inom, Isec, etc.) and the date and time in the CONF submenu.
- Choose and configure the communication buses in the Bus submenu.

Some of the parameters can only be changed via the RS-232 serial port using the VAMPSET software. Such parameters, (for example passwords) are normally set only during commissioning.

Some of the parameters require the restarting of the unit. This restarting is done automatically when necessary. If a parameter is tried to change the unit will inform about the auto-reset feature (see Figure 5-1).

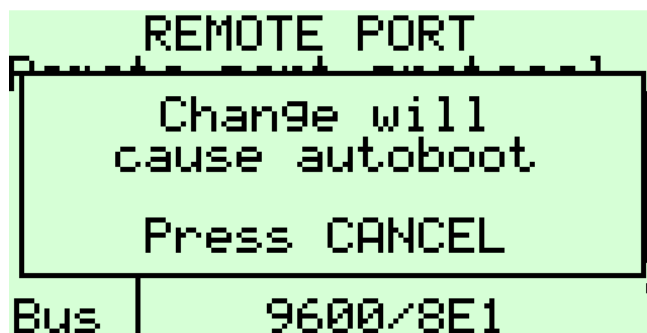

Figure 5-1. Example of auto-reset display

Press CANCEL to return to the setting view. If a parameter must be changed, press the ENTER key again. The parameter can now be set. When the parameter change is confirmed with the ENTER key, a [RESTART]-text appears to the top-right corner of the display. This means that auto-resetting is pending. If no key is pressed, the auto-reset will be executed within few seconds.

## 5.1. Principle of parameter setting

1. Move to the setting state of the desired menu (for example CONF/CURRENT SCALING) by pushing the ENTER key. The Pick text appears in the upper-left part of the display.
2. Enter the password associated with the configuration level by pushing the LEFT and RIGHT keys simultaneously and then using the arrow keys and the ENTER key (default value = 0002). For more information about the operating levels, please refer to 3.2.
3. Scroll through the parameters using the UP and DOWN keys. A parameter can be set if the background color of the line is black. If the parameter cannot be set the parameter is framed.
4. Select the desired parameter (for example Inom) with the ENTER key.
5. Use the UP and DOWN keys to change a parameter value. If the value contains more than one digit, use the LEFT and RIGHT keys to shift from digit to digit, and the UP and DOWN keys to change the digits.
6. Push the ENTER key to accept a new value. If you want to leave the parameter value unchanged, exit the edit state by pushing the CANCEL key.

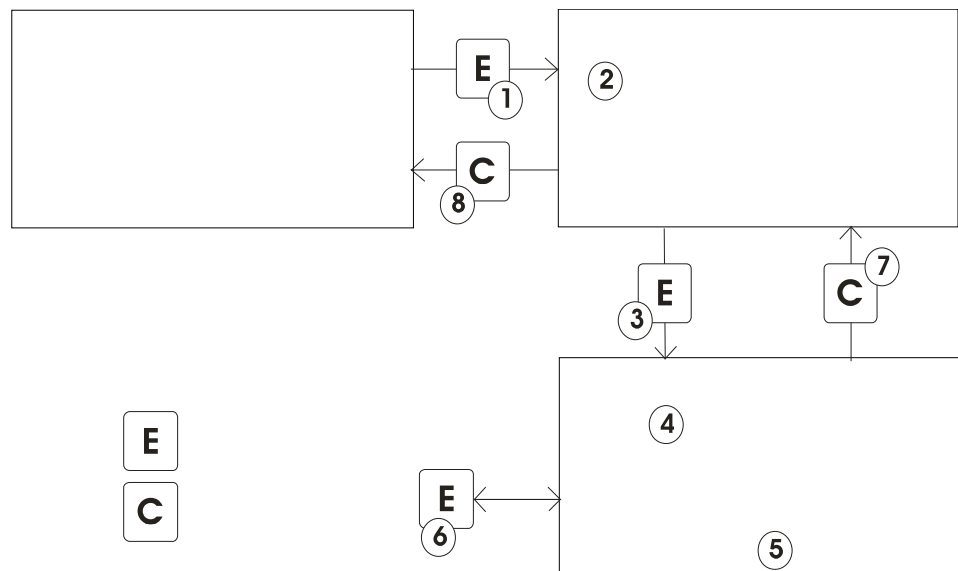

Figure 5.1-1. Changing parameters

## 5.2. Disturbance recorder menu DR

Via the submenus of the disturbance recorder menu the following functions and features can be read and set:

### DISTURBANCE RECO

- Recording mode (Mode)
- Sample rate (Rate)
- Recording time (Time)
- Count of ready records (ReadyRe)

### REC. COUPLING

- Add a link to the recorder (AddLink)
- Clear all links (ClrLnks)

### Available links:

- DO, DI
- Uline, Uphase
- IL
- U2/U1, U2, U1
- I2/In, I2/I1, I2, I1, IoCalc
- CosFii
- PF, S, Q, P
- f
- UL3, UL2, UL1
- U31, U23, U12
- Io
- IL3, IL2, IL1
- Prms, Qrms, Srms
- Tanfii
- THDIL1, THDIL2, THDIL3
- THDUa, THDUb, THDUc
- fy, fz, U12y, U12z

## 5.3. Configuring digital inputs DI

The following functions can be read and set via the submenus of the digital inputs menu:

- The status of digital inputs (DIGITAL INPUTS 1-3)
- Operation counters (DI COUNTERS)
- Operation delay (DELAYs for DigIn)
- Operation DI NO /NC, alarm display, event mask (on/off event)
- The status of virtual inputs (VIRTUAL INPUTS 1-4)

## 5.4. Configuring digital output

The following functions can be read and set via the submenus of the digital output menu:

- The status of the output relay
- The configuration of the output signal to the output relay.  
The configuration of the operation indicator (LED) alarm.

## 5.5. Configuration menu CONF

The following functions and features can be read and set via the submenus of the configuration menu:

### DEVICE SETUP

- Transfer rate of local serial bus (bit/s)
- “AccessLevel” display (Acc)

### LANGUAGE

- Language selection

### CURRENT SCALING

- Rated phase CT primary current (Inom)
- Rated phase CT secondary current (Isec)
- Rated Io CT primary current (Ionom)
- Rated Io CT secondary current (Iosec)
- The rated current of the Io current input (Ioinp)

### VOLTAGE SCALING

- Rated VT primary voltage (Uprim)
- Rated VT secondary voltage (Usec)
- Voltage measuring mode (Umode)

**UNITS FOR MIMIC**

- Unit for voltage (V/kV)
- Unit for power (kW/MW)

**FUNDAMENTAL/RMS**

- Energy calculation mode
- Display fundamental measurements
- Display RMS measurements

**DEVICE INFO (only display)**

- Unit type
- Serial number (SerN)
- Software version (PrgVer)
- Bootcode version (BootVer)

**DATE/TIME SETUP**

- Date (Dat)
- Time (Time)
- Date information format (Style)

**CLOCK SYNC**

- Minute sync pulse DI (SyncDI)
- Sync correction (SyOS)
- RTC trim (CkTrim)
- Synchronizing source (SySrc internal)
- Time zone for NTP (TZone)
- NTP daylight saving time (DST)

## 5.6. Protocol menu Bus

**REMOTE PORT**

- The communication protocol of the REMOTE port (Protoc)
- Message counter (Msg#)
- Communication error counter (Errors)
- Communication time-out counter (Tout)

**LOCAL PORT**

- Normally none
- SPA bus
- Extension port

## MODBUS

- The device slave number at Modbus Slave Protocol or the target slave number at Modbus Master Protocol (Addr)
- Modbus transfer rate (bit/s)
- Modbus parity check (Parity)
- External I/O (bit/s, addresses)

## SPA BUS SLAVE

- Slave number (Addr) when a unit is connected to SPA bus
- SPA bus transfer rate (bit/s)

## IEC 60870-5-103

- Slave address (Addr)
- Transfer rate (bit/s)
- Measurement interval (MeasIn)
- Time synchronization response mode (Sync)

## IEC 60870-5-103 DISTURBANCE RECORDER

- ASDU23 activation (ASDU23)
- samples per message (smpls/msg)
- Time out
- DR Debug
- Fault
- Tag position
- Chn
- ChnPos

## PROFIBUS DP

- Profibus profile (Mode)
- The transfer rate of the converter (bit/s)
- Profibus Tx Buf length (InBuf)
- Profibus Rx Buf length (OutBuf)

**DNP 3.0**

- Transfer rate (bit/s)
- Parity
- Slave address (SlvAddr)
- Master address (MstrAddr)
- Link layer confirmation timeout (LLTout)
- Link layer retry counter (LLRetry)
- Application layer confirmation timeout (APLTout)
- CNF Mode
- Double-Bit input supply (DBISup)

**TCP/IP**

- The IP address of the unit (Ip)
- Subnet mask (N)
- The IP address of the Gateway (Gatew)
- The IP address of the Name Server (NameSv)
- The IP address of the SNTP Server (NTPSvr)
- The port number used in remote protocol (e.g. ModbusTCP) communication (Port)

## 6. PC software

### 6.1. PC user interface

The PC user interface can be used for:

- On-site parameterization of the unit
- Loading unit software from a computer
- Reading measured values to a computer

Two RS 232 serial ports are available for connecting a local PC; one on the front panel and one on the rear panel of the unit.

The serial ports are connected in parallel. However, if the connection cables are connected to both ports, only the port on the front panel will be active. To connect a PC to a serial port, use a connection cable of type VX 003-3.

You can also use the VAMPSET software through a TCP/IP LAN connection. Optional hardware is required.

#### 6.1.1. Using VAMPSET program

For more information about the VAMPSET software, please refer to the user's manual with the code VMV.EN0xx. If the VAMPSET user's manual is not available, please download it from our web site at [www.vamp.fi](http://www.vamp.fi).

### 6.2. Remote control connection

The unit communicates with higher-level systems, e.g. remote control systems, via the serial port (REMOTE) on the rear panel of the unit.

Modbus RTU, SPA bus, IEC 60870-5-103, Profibus, ModbusTCP or DNP 3.0 can be used as REMOTE communication protocols (see details in the technical description).

Additional operation instructions for various bus types are to be found in their respective manual.

# 7. Commissioning configuration

## 7.1. Factory settings

When delivered from the factory, WIMO 6CP10 has got either factory default settings or settings defined by the customer. The configuration can be read from the workshop test reports or from the final test reports.

### 7.1.1. Configuration during commissioning

The settings of the unit can be defined and checked during the commissioning in accordance with the instructions given in chapter 5 of this manual. The order can be, for example, the following:

1. The scaling of the rated values of the phase currents (CONF/CURRENT SCALING menu)
2. The scaling of the rated values of the voltages (CONF/VOLTAGE SCALING menu)

The scaling is done in the software block of the measured signals (see Figure 7.1.1-1). Thus, the scaling will affect all the measuring functions.

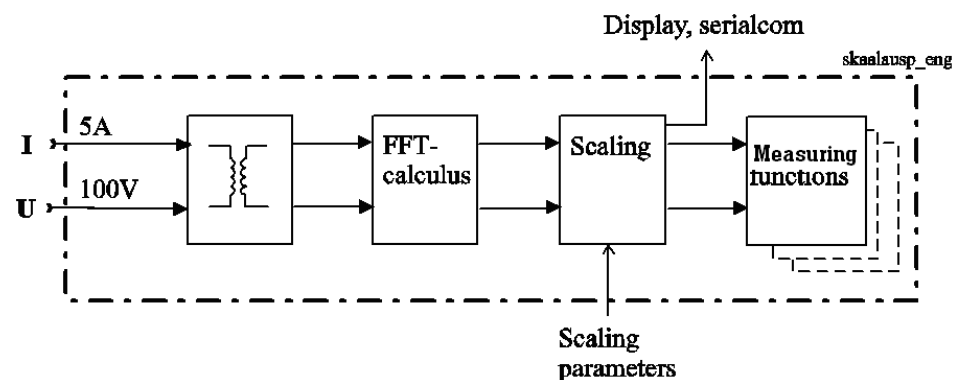

Figure 7.1.1-1. Principle for scaling the measured values of the unit

3. Configuration of communication parameters (Bus menu). See chapter 5.6 on page 23.
4. Set measurements displays via VAMPSET and LOCAL PANEL CONF.

MEASUREMENT DISPLAYS				
DISPLAY 1	DISPLAY 2	DISPLAY 3	DISPLAY 4	DISPLAY 5
IL1	U12	UL1	f	P.F.
IL2	U23	UL2	P	CosFii
IL3	U31	UL3	Q	-
TRTD	Uo	Uo	S	-

Display contrast	115
Enable alarmscreen	<input type="checkbox"/>
AR info for mimic display	<input type="checkbox"/>
Fault value scaling	PU

Figure 7.1.1-2. Choose measurements to local panel display

Table of Contents

- 1. Introduction .....31**
  - 1.1. Application..... 31
  - 1.2. Main features..... 32
- 2. Functions .....33**
  - 2.1. WIMO 6CP10 function dependencies..... 33
    - 2.1.1. Unit function reference guide ..... 33
  - 2.2. Programmable stage ..... 34
  - 2.3. Measurement functions ..... 35
    - 2.3.1. Fundamental frequency measurement ..... 35
    - 2.3.2. Power calculations..... 35
    - 2.3.3. Harmonics and Total Harmonic Distortion (THD) 37
    - 2.3.4. Voltage interruptions..... 37
    - 2.3.5. Voltage sags and swells ..... 39
  - 2.4. Control functions..... 40
    - 2.4.1. Local/Remote selection ..... 40
  - 2.5. Disturbance recorder ..... 40
- 3. Applications.....43**
  - 3.1. Secondary substation measuring and monitoring .... 43
  - 3.2. Accessories ..... 43
    - 3.2.1. Temperature measurement..... 44
    - 3.2.2. Earth fault alarm ..... 44
    - 3.2.3. Other accessories..... 44
- 4. Connections .....45**
  - 4.1. Rear panel view ..... 45
    - 4.1.1. WIMO 6CP10..... 45
  - 4.2. Analogue measurements ..... 46
  - 4.3. Digital inputs..... 46
  - 4.4. Output relay..... 46
  - 4.5. Serial communication connection..... 47
    - 4.5.1. Pin assignments of communication ports..... 47
    - 4.5.2. Protocols..... 48
  - 4.6. Connection examples..... 51
    - 4.6.1. WIMO 6CP10 secondary substation measuring and monitoring unit ..... 51
- 5. Technical data .....52**
  - 5.1. Connections..... 52
    - 5.1.1. Measuring circuitry ..... 52
    - 5.1.2. Auxiliary voltage ..... 52
    - 5.1.3. Digital inputs ..... 52
    - 5.1.4. Alarm contact..... 53
    - 5.1.5. Local serial communication port ..... 53
    - 5.1.6. Remote control connection ..... 53
  - 5.2. Tests and environmental conditions ..... 54
    - 5.2.1. Disturbance tests ..... 54
    - 5.2.2. Test voltages..... 54



---

5.2.3. Mechanical tests .....	54
5.2.4. Environmental conditions .....	54
5.2.5. Casing .....	54
5.2.6. Package.....	55
<b>6. Construction .....</b>	<b>56</b>
6.1. Dimensional drawing.....	56
<b>7. Order information.....</b>	<b>57</b>
7.1. Ordering codes of WIMO 6CP10 measuring and monitoring unit.....	57
<b>8. Reference information.....</b>	<b>58</b>

# 1. Introduction

This part of the user manual provides a few application examples and contains technical data.

## 1.1. Application

The numerical WIMO units include all the essential features needed to monitor secondary substations and to locate earth fault or short circuit in real time. Further, the unit includes communication protocols for various communication situations.

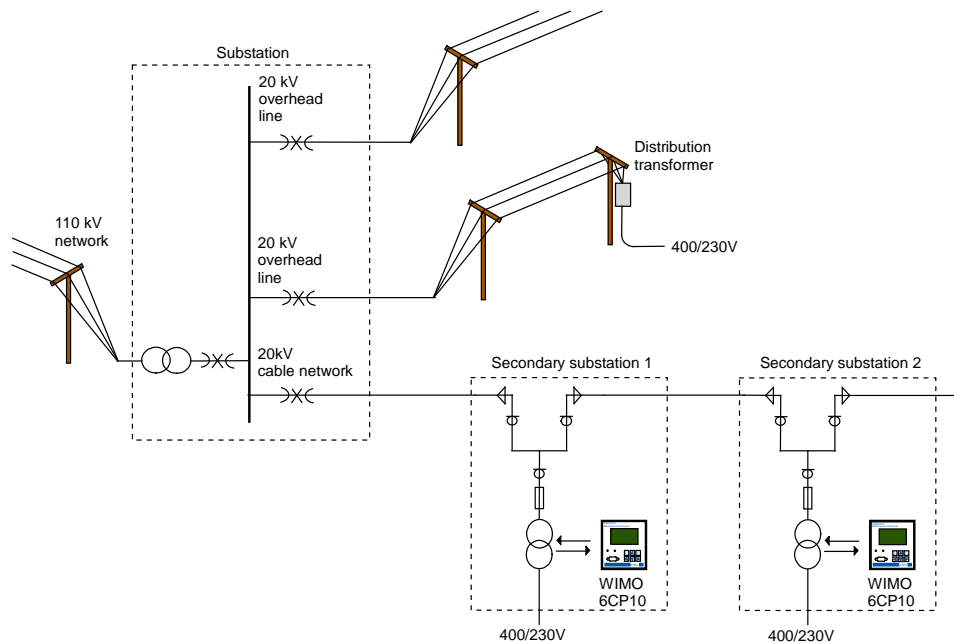

Figure 1.1-1. Application of the monitoring unit

Besides monitoring voltage, current, power etc in real time WIMO 6CP10 secondary substation measuring and monitoring unit can be used for monitoring and locating short circuits and earth faults. Earth fault, short circuit and many other special designed indicators can be attached into WIMO 6CP10 digital inputs. Digital input alarms are also reported for user in real time.

The modern technology and a reliable construction ensures an extremely high availability for WIMO 6CP10.

## 1.2. Main features

- Fully digital signal handling with a powerful 16-bit microprocessor, and high measuring accuracy on all the setting ranges due to an accurate 16-bit A/D conversion technique.
- Three universal digital inputs, short circuit detection, transformer condition monitoring, smoke detection, water detection, transformer door indicator etc.
- One relay output.
- 5 special displays to show the main measurements
- Recording of events and fault values into an event register.
- Latest events and indications are in non-volatile memory.
- Easy configuration, parameterisation and reading of information via local HMI, or with a VAMPSET user interface.
- Built-in, self-regulating dc/dc converter for auxiliary power supply from any source within the range from 100 to 240 V ac or 130-330 V dc.
- Built-in disturbance recorder for evaluating all the digital signals.
- Wide range of measurement functions including overload conditions, power outages, under voltage and over voltage disturbance, earth faults, current unbalance, reactive power, energy and temperature.
- Communications GPRS, SPA, OPC etc.
- Leased modem line.
- In case of earth-fault, WIMO 6CP10 registers the fault current which helps customer to locate the earth-fault.

## 2. Functions

### 2.1. WIMO 6CP10 function dependencies

#### 2.1.1. Unit function reference guide

Table of the unit dependent functions:

	IEC symbol	Function name	
Measurement functions	3I	Three-phase current	
	I <sub>0</sub>	Neutral current	
	I <sub>2</sub>	Current unbalance	
	I <sub>L</sub>	Average and maximum demand current	
	3U	Phase and line voltages	
	U <sub>2</sub>	Voltage unbalance	
	F	System frequency	
Measurement and monitoring functions	P	Active power	
	Q	Reactive power	
	S	Apparent power	
	E+, E-	Active Energy, exported / imported	
	Eq+, Eq-	Reactive Energy, exported / imported	
	PF	Power factor	
		Phasor diagram view of voltages	
		Phasor diagram view of currents	
	2nd to 15 <sup>th</sup> harmonics and THD of currents		
	2nd to 15 <sup>th</sup> harmonics and THD of voltages		
	Voltage interruptions		
	Voltage sags and swells		
Communication		IEC 60870-5-103	
		Modbus TCP	
		Modbus RTU	
		Profibus DP	
		SPA-bus communication	
	Man-Machine-Communication, display		
	Man-Machine-Communication, PC		
Hardware		Number of phase current CT's	3
		Number of residual current CT's	1
		Number of voltage input VT's	3
		Number of digital inputs	3
		Number of alarm outputs	1

## 2.2. Programmable stage

WIMO 6CP10 has eight identical programmable stages (PROGRAMMABLE STAGE 1-8). All programmable stages can be enabled or disabled one by one from the menu to fit the intended application. All the enabled programmable stages have the following programmable parameters:

- Link: link to a measured or calculated value, see table below.
- Cmp: mode (< or >)
- Pick-up: alarm limit of the stage (the setting range and the unit depend on the signal)
- t: operation delay 0.08 - 300.0 s, step 0.01 s or 0.02 s
- Hyster: hysteresis 0.2 – 10.0%, step 0.1%
- NoCmp: no compare limit (visible only for active < mode)

### Programmable stage link signals

Alarm stages link signals	Interval
P, Q, S, f, P.F, $\cos\phi$ , $\tan\phi$ Prms, Qrms, Srms IL1 – IL3, IL, IL max of IL1 – IL3 Io, Iocalc, I1, I2, I2/I1, I2/In U12, U23, U31, Uline UL1 – UL3, Uphase U1, U2, U2/U1 THDIL1, THDIL2, THDIL3, THDUa, THDUb, THDUc	Selectable 10ms, 20ms or 100ms

The outputs of the programmable stages can control output relay A1 and alarm LED, see Figure 2.2-1 and Figure 2.2-2.

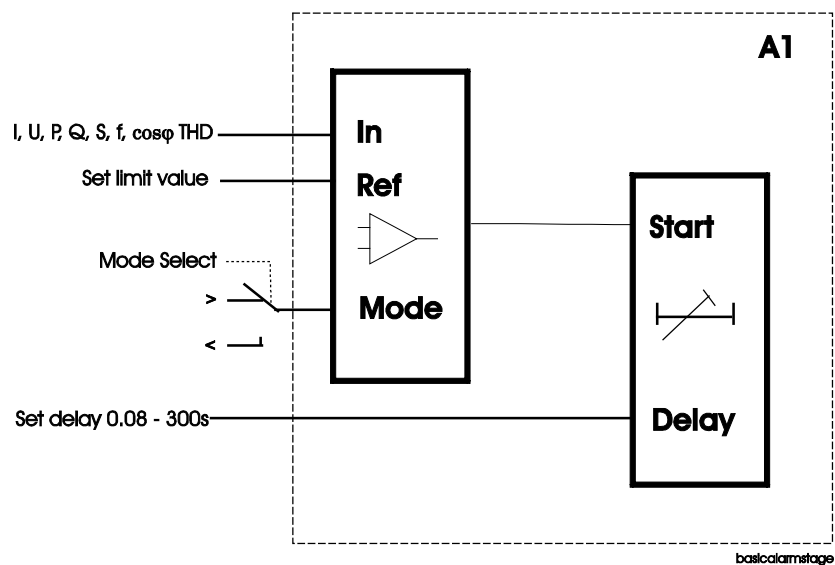

Figure 2.2-1 Principle of programmable stage

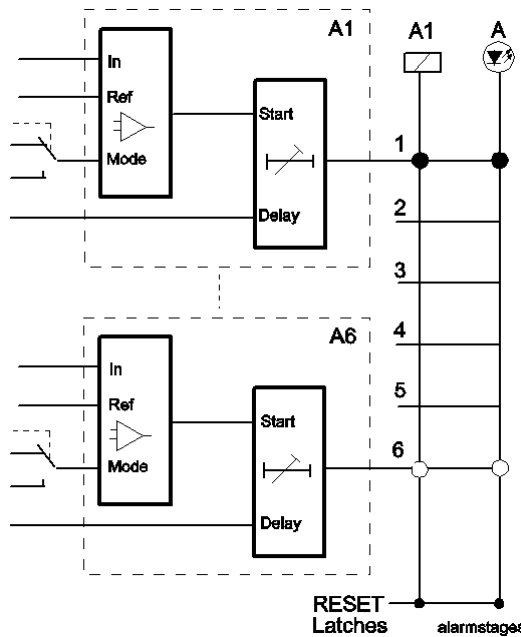

Figure 2.2-2 Programmable stages in the output matrix

## 2.3. Measurement functions

### 2.3.1. Fundamental frequency measurement

All the measurements, except frequency, are based on fundamental frequency values. They are not RMS values.

The device calculates the active (P), reactive (Q), apparent power (S) and energy measures (E+, Eq+, E-, Eq-) from voltage and current measurements.

#### Phase currents $I_{L1}, I_{L2}, I_{L3}$

Measuring range	$I_n = 5 \text{ A}$
-----------------	---------------------

#### Phase voltages $U_{L1}, U_{L2}, U_{L3}$

Measuring range	90...265 V ac
-----------------	---------------

#### Earth fault currents $I_0$

Measuring range	$I_0 < 50 \text{ A}$
-----------------	----------------------

#### Frequency f

Measuring range	45 - 65 Hz
-----------------	------------

### 2.3.2. Power calculations

The formulas used by the unit for power calculations are found in this chapter

### Phase to neutral voltages measured

Active power calculation for one phase:

$$P_{L1} = U_{L1} \cdot I_{L1} \cdot \cos \varphi$$

Reactive power calculation for one phase:

$$Q_{L1} = U_{L1} \cdot I_{L1} \cdot \sin \varphi$$

where,

$U_{L1}$  = Measured L1 phase voltage

$I_{L1}$  = Measured L1 current

$\varphi$  = Angle between  $U_{L1}$  and  $I_{L1}$

Active, reactive and apparent power are calculated as follows:

$$P = P_{L1} + P_{L2} + P_{L3}$$

$$Q = Q_{L1} + Q_{L2} + Q_{L3}$$

$$S = \sqrt{P^2 + Q^2}$$

$$\cos \varphi = \frac{P}{S}$$

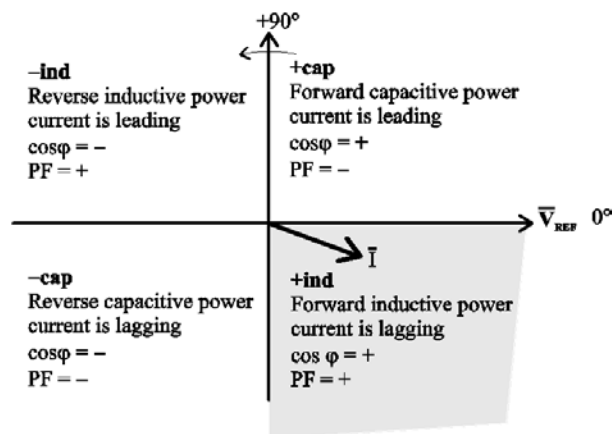

Figure 2.3.2-1 Quadrants of voltage/current phasor plane

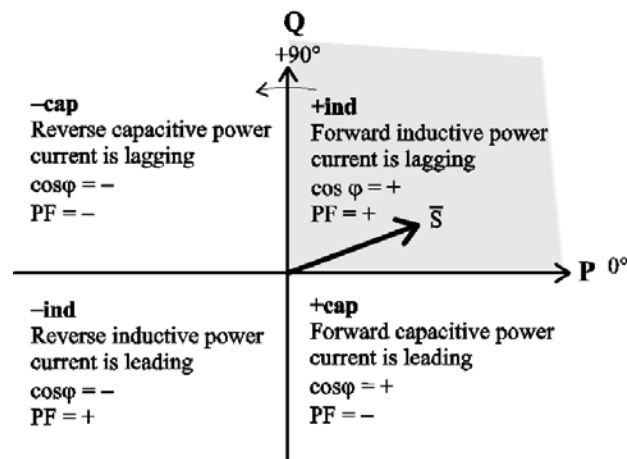

Figure 2.3.2-2 Quadrants of power plane

Power quadrant	Current related to voltage	Power direction	cosφii	Power factor
+ inductive	Lags	Forward	+	+
+ capacitive	Leads	Forward	+	-
- inductive	Leads	Reverse	-	+
- capacitive	Lags	Reverse	-	-

### 2.3.3. Harmonics and Total Harmonic Distortion (THD)

The device calculates the THDs as percentage of the base frequency for currents and voltages.

The device calculates the harmonics for phase currents and phase voltages from the 2nd to the 15th order. (The 17<sup>th</sup> harmonic component will also be shown partly in the value of the 15<sup>th</sup> harmonic component. This is due to the nature of digital sampling.)

### 2.3.4. Voltage interruptions

WIMO 6CP10 includes a simple function to detect and measure voltage sags.

The function calculates the number of voltage interruptions and the total time of the voltage interruptions within a period. The period is based on the real time clock of the device. The available periods are:

- 8 hours, 00:00 – 08:00, 08:00 – 16:00, 16:00 – 24:00
- one day, 00:00 – 24:00
- one week, Monday 00:00 – Sunday 24:00
- one month, the first day 00:00 – the last day 24:00
- one year, 1<sup>st</sup> January 00:00 – 31<sup>st</sup> December 24:00

After each period, the number of interruptions and the total interruption time are stored as previous values. The interruption counter and the total time are cleared for a new period. The pre-previous values are overwritten.

The voltage interruption is based on the value of the positive sequence voltage  $U_1$  and a user given limit value  $U_1 <$ .

Whenever the measured  $U_1$  goes below the limit, the interruption counter is increased, and the total time starts cumulating.

Shortest recognized interruption time is 40 ms. If the voltage-off time is shorter it may be recognized depending on the depth of the voltage dip, the ratio of the limit and the voltage value before the dip.

If the voltage has been significantly over the limit  $U_{1<}$  and then there is a small and short under swing, it will not be recognized (Figure 2.3.4-1).

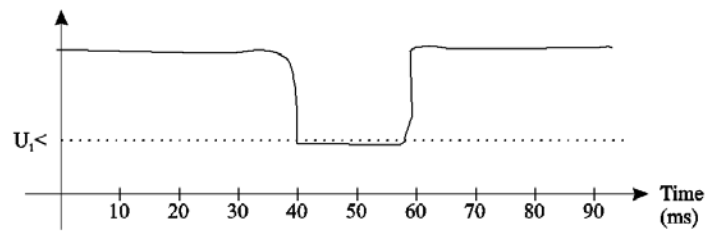

Figure 2.3.4-1. Short voltage sag which is probably not recognized

On the other hand, if the limit  $U_{1<}$  is high and the voltage has been near this limit, and then there is a short but very deep dip, it will be recognized (Figure 2.3.4-2).

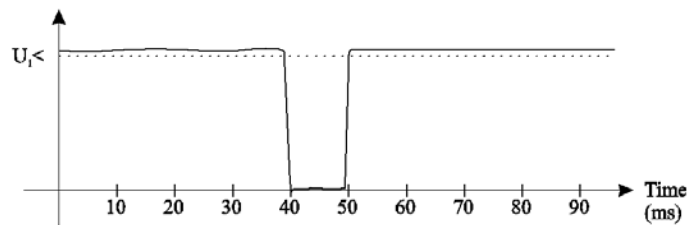

Figure 2.3.4-2. Short voltage sag that is recognized

### Setting parameters of the voltage sag measurement function:

Parameter	Value	Unit	Default	Description
$U_{1<}$	10.0 ... 120.0	%	64	Setting value
Period	8h; Day; Week; Month	-	Month	Length of the observation period
Date		-	-	Date
Time		-	-	Time

### Measured and recorded values of voltage sag measurement function:

	Parameter	Value	Unit	Description
Measured value	Voltage	LOW; OK	-	Current voltage status
	$U_1$		%	Measured positive sequence voltage
Recorded values	Count		-	Number of voltage sags during the current observation period
	Prev		-	Number of voltage sags during the previous observation period

Recorded values	Parameter	Value	Unit	Description
	Total		s	Total (summed) time of voltage sags during the current observation period
	Prev		s	Total (summed) time of voltage sags during the previous observation period

### 2.3.5. Voltage sags and swells

The power quality of electrical networks has become increasingly important. The sophisticated loads (e.g. computers etc.) require uninterrupted supply of “clean” electricity. One of the most important power quality functions are sag monitoring and swell monitoring.

The voltage log is triggered, if any voltage input either decreases under the sag limit (U<) or increases over the swell limit (U>). There are four registers for both sags and swells in the fault log. Each register will have start time, type (which phases), duration, minimum, average, maximum voltage values of each sag and swell event. Furthermore, there are total number of sags and swells counters as well as total timers for sags and swells.

The voltage power quality functions are located under the submenu “U”.

#### Setting parameters of sags and swells monitoring:

Parameter	Value	Unit	Default	Description
U>	20 ... 150	%	110	Setting value of swell limit
U<	10 ... 120	%	90	Setting value of sag limit
Delay	0.04 ... 1.00	S	0.06	Delay for sag and swell detection
SagOn	On; Off	-	On	Sag on event
SagOff	On; Off	-	On	Sag off event
SwelOn	On; Off	-	On	Swell on event
SwelOf	On; Off	-	On	Swell off event

#### Recorded values of sags and swells monitoring:

	Parameter	Value	Unit	Description
Recorded values	Count		-	Cumulative sag counter
	Total		-	Cumulative sag time counter
	Count		-	Cumulative swell counter
	Total		-	Cumulative swell time counter
				Sag/swell logs 1...4
	Date		-	Date of the sag/swell
	Time		-	Time stamp of the sag/swell
	Type		-	Voltage inputs that had the sag/swell



	Parameter	Value	Unit	Description
Recorded values	Time		s	Duration of the sag/swell
	Min1		%Un	Minimum voltage value during the sag/swell in the input 1
	Min2		%Un	Minimum voltage value during the sag/swell in the input 2
	Min3		%Un	Minimum voltage value during the sag/swell in the input 3
	Ave1		%Un	Average voltage value during the sag/swell in the input 1
	Ave2		%Un	Average voltage value during the sag/swell in the input 2
	Ave3		%Un	Average voltage value during the sag/swell in the input 3
	Max1		%Un	Maximum voltage value during the sag/swell in the input 1
	Max2		%Un	Maximum voltage value during the sag/swell in the input 2
	Max3		%Un	Maximum voltage value during the sag/swell in the input 3

## 2.4. Control functions

### 2.4.1. Local/Remote selection

In Local mode, the output relay can be controlled via a local HMI, but it cannot be controlled via a remote serial communication interface.

In Remote mode, the output relay cannot be controlled via a local HMI, but it can be controlled via a remote serial communication interface.

The selection of the Local/Remote mode is done by using a local HMI, or via one selectable digital input. The digital input is normally used to change a whole station to a local or remote mode. The selection of the L/R digital input is done in the “Objects” menu of the VAMPSET software.

#### NOTE!

A password is not required for a remote control operation.

## 2.5. Disturbance recorder

The disturbance recorder can be used to record all the measured signals, that is, currents, voltages and the status information of digital inputs (DI) and digital output (DO).

At the maximum, there can be 5 recordings, and the maximum selection of channels in one recording is 12 (limited in waveform recording). The digital inputs reserve one channel (includes all the inputs). Also the digital output reserves one channel.

The recorder can be triggered by a digital input. The trig signal is selected in the output matrix (signal DR). The recording can also be triggered manually.

When a recording is made, also the time stamp will be memorized.

The recordings can be uploaded, viewed and analysed with the VAMPSET program (version 8.x or newer).

For more detailed information about, for example, uploading, please see a separate VAMPSET manual.

### Available links

The following channels can be linked to a disturbance recorder:

- DO, DI
- Uline, Uphase
- IL
- U2/U1, U2, U1
- I2/In, I2/I1, I2, I1, IoCalc
- CosFii
- PF, S, Q, P
- f
- UL3, UL2, UL1
- U31, U23, U12
- Io
- IL3, IL2, IL1
- Prms, Qrms, Srms
- Tanfii
- THDIL1, THDIL2, THDIL3
- THDUa, THDUb, THDUc
- fy, fz, U12y, U12z

### NOTE!

The available channels (that is, what signals are measured) depend on the configuration.

## Disturbance recorder parameters

	Parameter	Value	Unit	Description
Setting values	Mode	Saturated; Overflow	-	Mode of the recording
	Rate	32 samples/cycle; 16 samples/cycle; 8 samples/cycle; 10ms; 20ms; 200ms; 1s; 5s; 10s; 15s; 30s; 1min;	-	Sample rate
	Time		s	Recording time (the maximum time calculated automatically)
	PreTrig	0 ... 100	%	Pre-trigger time
	MnlTrig	-;Trig	-	Manual trig
	Size			Size of one recording
	MAX time		s	The maximum time of recordings
	MAX size			Maximum size of recordings
	Recorder links	Links		
AddLink				Add links
ClrLnks				Clear links
Recorded values	Status			Status of recorder
	Time status		%	Status of pre-triggering
	ReadyRec		-	The number of ready records

# 3. Applications

The following example illustrate the versatile functions of WIMO 6CP10.

## 3.1. Secondary substation measuring and monitoring

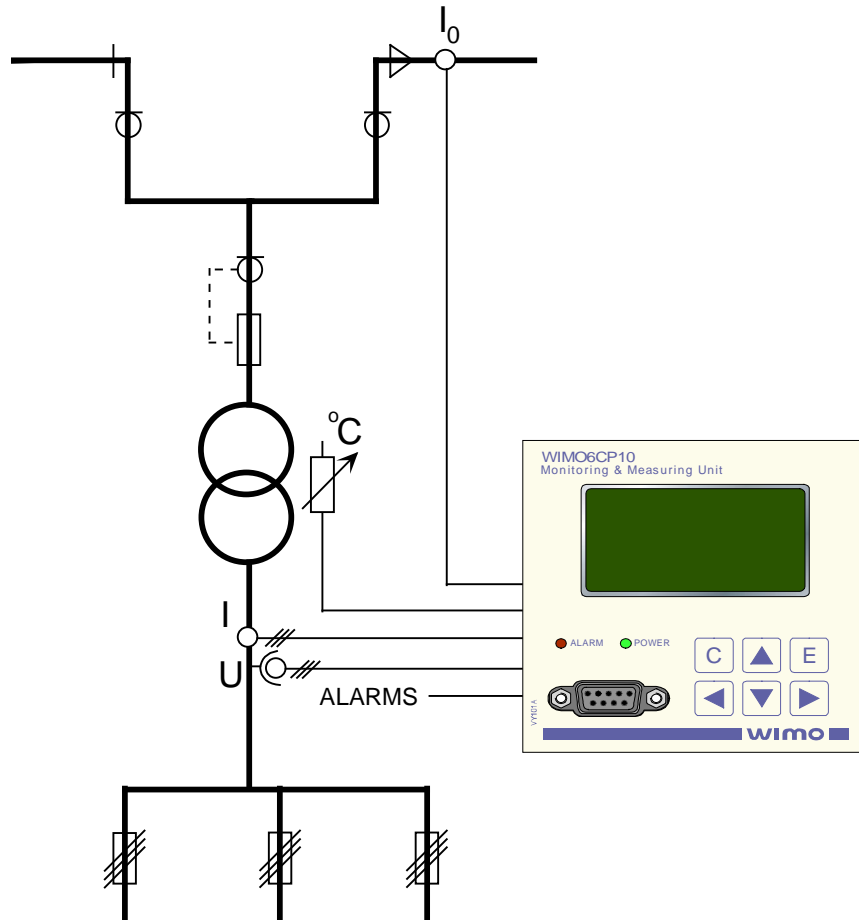

Figure 3.1-1 WIMO 6CP10 used in secondary substation monitoring

WIMO unit includes three-phase voltage, three-phase current and earth fault measuring. Unit measures also the temperature of the transformer.

WIMO 6CP10 is included with three digital inputs for various alarm stages as short circuit measurement or smoke detector.

## 3.2. Accessories

It is possible to connect various alarm indicators to WIMO 6CP10's digital inputs.

### 3.2.1. Temperature measurement

Temperature measurement is possible by connecting a Pt100 sensor to the device. The wiring resistance effect can be compensated by programming the resistance to the device.

In RTD menu, the parameter  $R_{cable}$  is set equal to measured resistance of the wiring. By using the WIMO TEMP Pt100 sensor, there would not be any setting changes required.

The Pt100 sensor is connected to the terminals X2B 6-7.

### 3.2.2. Earth fault alarm

Earth fault location in ungrounded networks is difficult. By using a Cabletroll 2000 earth fault sensor in WIMO 6CP10 devices installed in the network makes it possible to locate the earth faults. The Cabletroll 2000 is connected to terminals X2B 1-2.

**NOTE!** The terminal X2B 2 has to be grounded.

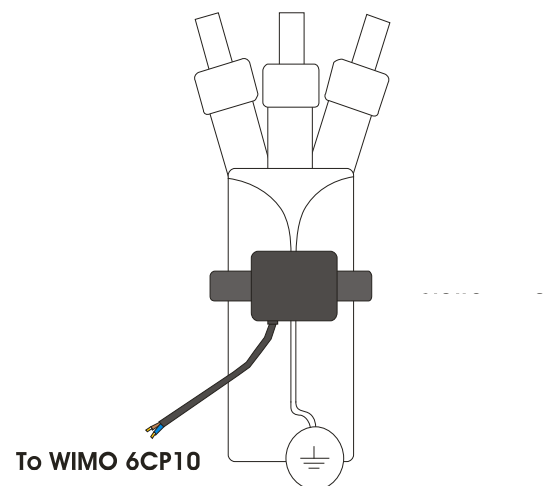

*Figure 3.2-1 Cabletroll 2000 attached to the cable of secondary substation*

No parameter setting is needed when connecting the Cabletroll 2000 to the WIMO 6CP10.

**NOTE!**

Make sure that the cable shielding goes beneath the Cabletroll 2000.

### 3.2.3. Other accessories

WIMO 6CP10 has 3 digital inputs. For example short circuit indicators can be connected to locate short circuit faults. Other possible sensors or indicators are smoke sensors, moisture sensors, door switches, fan alarms spray paint sensors, etc.

# 4. Connections

## 4.1. Rear panel view

### 4.1.1. WIMO 6CP10

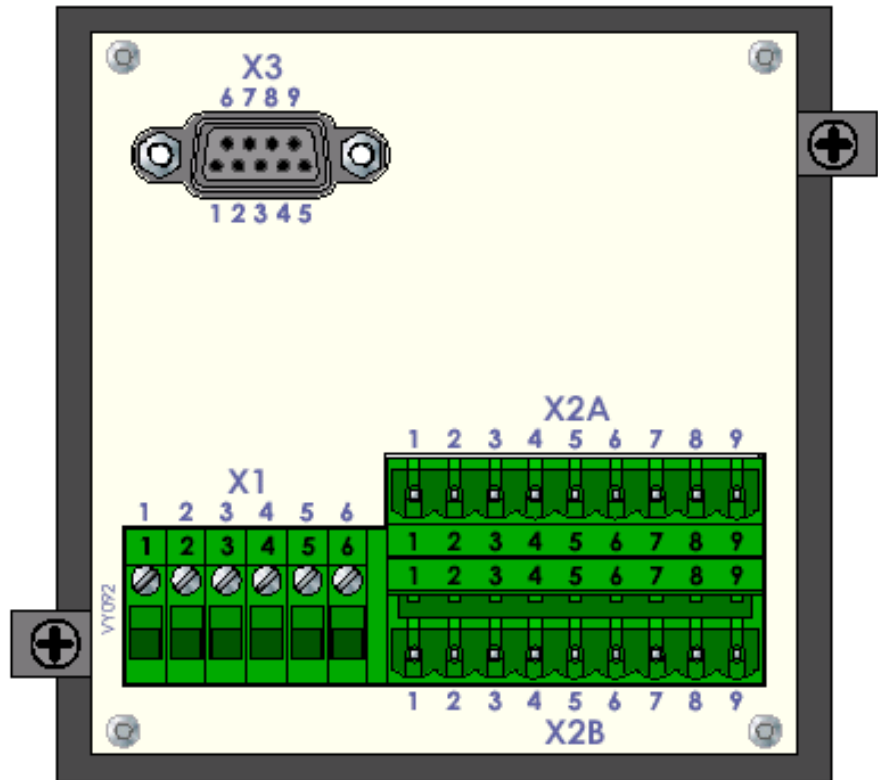
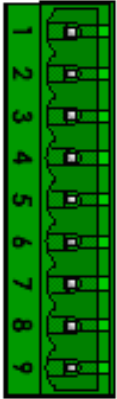

Figure 4.1.1-1 Connections on the rear panel of the WIMO 6CP10

#### Terminal X1

No:	Symbol	Description
1	IL1	Phase current L1
2	IL1	Phase current L1
3	IL2	Phase current L2
4	IL2	Phase current L2
5	IL3	Phase current L3
6	IL3	Phase current L3

**Terminal X2A**

No:	Symbol	Description
1	Uaux	Auxiliary voltage (contact in parallel with one of phases L1-L3)
2	PEN	PEN
3	UL3	Phase voltage L3
4	UL2	Phase voltage L2
5	UL1	Phase voltage L1
6	--	--
7	NO	Relay normal open
8	COMMON	Relay common
9	NC	Relay normal close

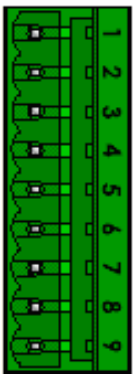
**Terminal X2B**

No:	Symbol	Description
1	Io	Earth fault current Io
2	Io	Earth fault current Io
3	DI1	Digital input 1
4	DI2	Digital input 2
5	DI3	Digital input 3
6	PT100	RTD input (PT 100)
7	PT100	RTD input (PT 100)
8	+12V	+12V out
9	DGND	Ground DGND

## 4.2. Analogue measurements

- Phase currents  $I_{L1}$ ,  $I_{L2}$  and  $I_{L3}$  (terminals X1: 1-6)
- Earth fault current  $I_0$  (terminals X2B: 1-2)
- Phase voltages  $U_{L1}$ ,  $U_{L2}$  and  $U_{L3}$  (terminals X2A: 3-5)

## 4.3. Digital inputs

Further, the unit can collect status information and alarm signals via 3 digital inputs (terminals X2B: 3-5). The three digital inputs in WIMO use an internal 12 V dc auxiliary voltage of the unit (terminal X2B: 8).

Potential-free contacts must be available in the protected object for transferring status information to the unit.

## 4.4. Output relay

The terminal is equipped with one output relay.

- Output relay (terminals X2A: 7-9)

## 4.5. Serial communication connection

- RS 232 serial communication connection for computers, connector LOCAL (RS 232), the connectors on the front and rear panel are connected in parallel.
- Remote control connection with the following options:
  1. TTL (9-pin)
  2. RS-485 (9-pin)
  3. Plastic fibre
  4. Glass fibre
  5. Profibus RS-485 (9-pin)

### 4.5.1. Pin assignments of communication ports

The pin assignment of remote port is presented in the following table (Figure 4.5.1-1)

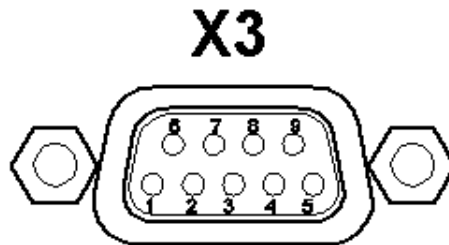

Figure 4.5.1-1. Pin numbering of the rear communication port, REMOTE

Port (REMOTE)	Pin	Signal
X3	1	
X3	2	TX remote
X3	3	RX remote
X3	4	
X3	5	TX local
X3	6	RX local
X3	7	GND
X3	8	
X3	9	+8V

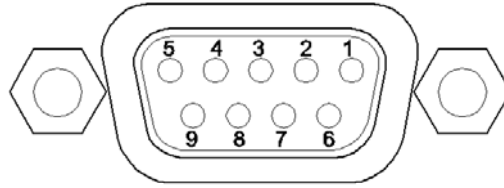

Figure 4.5.1-2. Pin numbering of the front communication port

Port (LOCAL)	Pin	Signal
Front	1	
Front	2	RX / RS232 in
Front	3	TX / RS232 out
Front	4	+12V out
Front	5	GND
Front	6	DSR in
Front	7	
Front	8	
Front	9	

#### NOTE!

DSR must be connected to +12V to activate the front panel interface.

## 4.5.2.

### Protocols

#### SPA bus

WIMO 6CP10 has full support for the SPA bus protocol including the following features:

- event transfer
- the transfer of status data
- the transfer of measurement data
- the reception of control commands
- the reading and writing of setting values
- the reading of multiple consecutive status data bits, measurement values or setting values with one message.

The physical connection from a unit is by default 9-pin D-connector with TTL level signals. This can only be used to connect to an external bus connection device or to a modem. Alternatively, a TTL/RS-232 conversion cable can be used with this serial port.

The unit can be equipped with a fibre optic option module, which includes fibre optic connectors (two plastic/two glass/one plastic and one glass).

### Modbus RTU

WIMO 6CP10 is also available with Modbus RTU slave or Modbus RTU master. These are often used in power plants or in industrial applications. The protocols enable the transfer of the following data:

- events
- statuses
- measurements and
- control commands.

The Modbus communication is activated via a menu selection. The Modbus RTU protocols can be used with RS-232, RS-485 or the fibre optic interface.

### ModbusTCP

WIMO 6CP10 is also available with the ModbusTCP protocol. This is often used in power plants or in industrial applications. The protocol enables the transfer of the same data as with the Modbus RTU slave protocol.

The ModbusTCP communication is activated via a menu selection. The use of ModbusTCP requires an external Ethernet module (VEA 3CG).

### Profibus

WIMO 6CP10 is also available with Profibus (Profibus DP slave) protocol. This is often used in power plants and in industrial applications. The protocols enable the transfer of the following data:

- events
- statuses
- measurements and
- control commands.

The Profibus communication is activated via a menu selection. An external or an internal Profibus module is required.

### IEC 60870-5-103

The IEC standard 60870-5-103 "Companion standard for the informative interface of protection equipment" provides standardized communication interface to a primary system (master system).

The unbalanced transmission mode of the protocol is used, and the unit functions as a secondary station (slave) in the communication. Data is transferred to the primary system using "data acquisition by polling"-principle. The IEC functionality includes the following application functions:

- station initialization
- general interrogation
- clock synchronization and
- command transmission.

It is not possible to transfer parameter data or disturbance recordings via the IEC 103 protocol interface.

### DNP 3.0

WIMO 6CP10 supports communication using DNP 3.0 protocol.

The following DNP 3.0 data types are supported:

- binary input
- binary input change
- double-bit input
- binary output
- analog input
- counters

Additional information can be obtained from the DNP 3.0 Device Profile Document.

DNP 3.0 communication is activated via menu selection. RS-485 interface is often used but also RS-232 and fibre optic interfaces are possible.

## 4.6. Connection examples

### 4.6.1. WIMO 6CP10 secondary substation measuring and monitoring unit

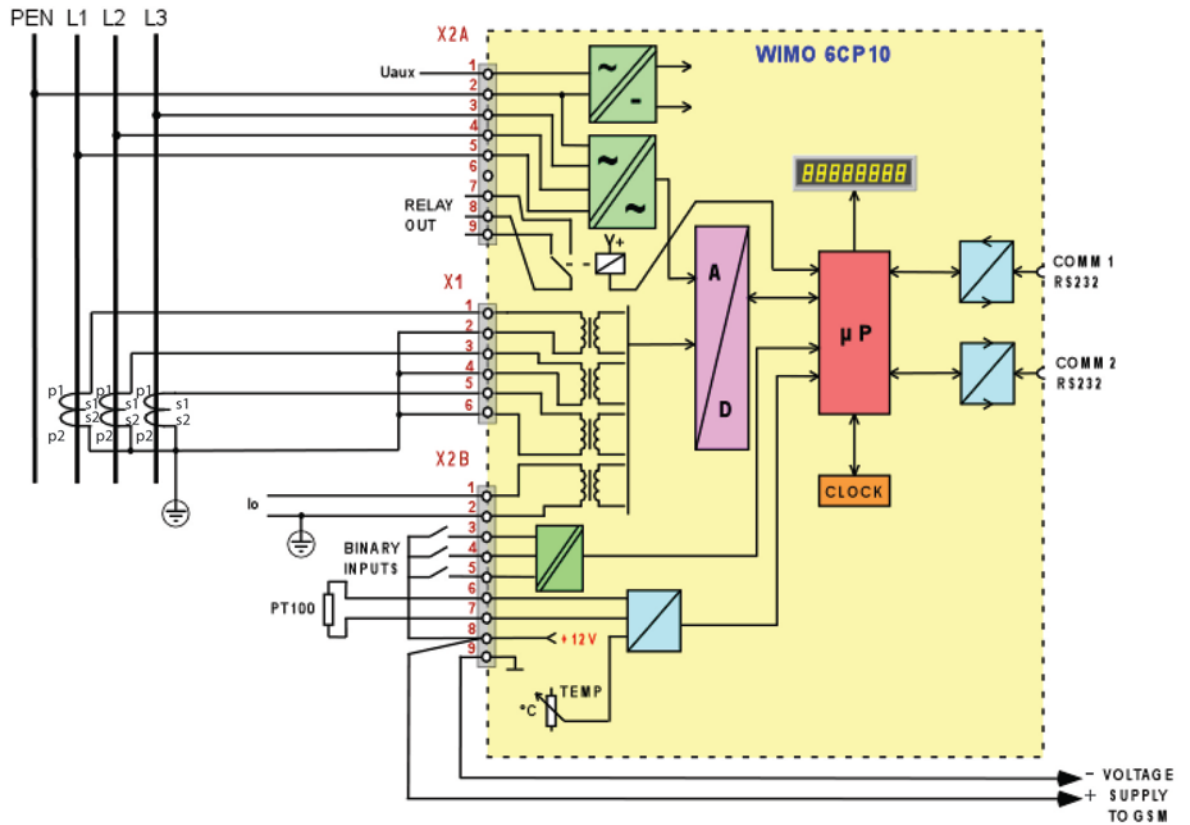

Figure 4.6.1-1 Connection example of WIMO 6CP10

## 5. Technical data

### 5.1. Connections

#### 5.1.1. Measuring circuitry

Rated current $I_n$ - Current measuring range - Thermal withstand - Burden	5 A 0-5 A 6 A (continuously) < 0.1 VA
Rated current $I_{0n}$ - Current measuring range	50 mA 0...100 mA
Rated voltage $U_n$ - Voltage measuring range - Continuous voltage withstand - Burden	230 V ac 90 – 265 V ac 275 V ac < 0.5 VA
Rated frequency $f_n$ - Frequency measuring range	50 Hz 45 – 65 Hz
Terminal block: - Solid or stranded wire	Maximum wire dimension: 2,5 mm <sup>2</sup> (13-14 AWG)

#### 5.1.2. Auxiliary voltage

	Type A (standard)
Rated voltage $U_{aux}$	100 - 240 V ac 110 - 330 V dc 110/120/220/240 V ac
Power consumption	< 10 W (normal conditions) < 15 W (output relay activated)
Max. permitted interruption time	< 15 ms (230 V ac)
Terminal block: - Phoenix MVSTBW or equivalent	Maximum wire dimension: 2.5 mm <sup>2</sup> (13-14 AWG)

#### 5.1.3. Digital inputs

##### Internal operating voltage

Number of inputs	3
Internal operating voltage	12 V dc
Current drain when active (max.)	Approx. 5 mA
Current drain, average value	< 2,5 mA
Terminal block: - Phoenix MVSTBW or equivalent	Maximum wire dimension: 2.5 mm <sup>2</sup> (13-14 AWG)

### 5.1.4. Alarm contact

Number of contacts:	1 change-over contact relay
Rated voltage	48 V ac
Max. make current	N.O. 10 A / N.C. 3 A
Continuous carry	3 A
Breaking capacity, ac	N.O. 1250 VA / N.C. 500 VA
Contact material	Max. wire dimension: 2.5 mm <sup>2</sup> (13-14 AWG)
Terminal block	
- Phoenix MVSTBW or equivalent	

### 5.1.5. Local serial communication port

Number of ports	1 on front and 1 shared on rear panel
Electrical connection	RS 232
Data transfer rate	9600 - 38 400 kb/s

### 5.1.6. Remote control connection

Number of ports	1 shared on rear panel
Electrical connection	RS 232 (standard) RS 485 (with external module) TTL Plastic fibre connection (with external module)
Data transfer rate	9600 kb/s
Protocols	Modbus, RTU master Modbus, RTU slave SPA bus, slave IEC 60870-5-103 Profibus DP (option) TCP/IP (option) DNP 3.0



## 5.2. Tests and environmental conditions

### 5.2.1. Disturbance tests

Emission	
- Conducted (EN 55022B)	0.15 – 30 MHz
- Emitted (CISPR 11)	30 – 1000 MHz
Immunity	
- Static discharge (ESD)	EN 61000-4-2, class III 6 kV contact discharge 8 kV air discharge
- Fast transients (EFT)	EN 61000-4-4, class III 2 kV, 5/50 ns, 5 kHz, +/-
- Surge	EN 61000-4-6, class III 1 kV, 1.2/50 $\mu$ s, common mode 2 kV, 1.2/50 $\mu$ s, differential mode
- Conducted HF field	EN 61000-4-6 0.15 – 80 MHz, 10 V/m, 80% AM (1 kHz)
- Emitted HF field	EN61000-4-3 80 – 1000 MHz, 10 V/m, 80% AM (1 kHz)
- GSM test	EN 61000-4-3 900 MHz, 10 V/m, pulse modulated
1 MHz burst	IEC 60255-22-1 1 kV, differential mode 2.5 kV, common mode
Voltage interruption	IEC 60255-11

### 5.2.2. Test voltages

Insulation test voltage (IEC 60255-5)	2 kV, 50 Hz, 1 min
Surge voltage (IEC 60255-5)	5 kV, 1.2/50 $\mu$ s, 0.5 J

### 5.2.3. Mechanical tests

Vibration (IEC 60255-21-1)	10...60 Hz, amplitude $\pm 0.035$ mm 60...150 Hz, acceleration 0.5 g Sweep rate 1 octave/min 20 periods in X-, Y- and Z axis direction
Shock (IEC 60255-21-1)	Half sine, acceleration 5 g, duration 11 ms 3 shocks in X-, Y- and Z axis direction

### 5.2.4. Environmental conditions

Operating temperature	-25 to +50 °C
Operating temperature (display)	0 to +50 °C
Transport and storage temperature	-10 to +60 °C
Relative humidity	< 75% (1 year, average value) < 90% (30 days per year, no condensation permitted)

### 5.2.5. Casing

Degree of protection (IEC 60529)	IP20
Dimensions (W x H x D)	96 x 96 x 151 mm
Material	Polyphenylene oxide
Weight	1.2 kg
Colour code	

## 5.2.6.

**Package**

Dimensions (W x H x D)	105 x 105 x 175 mm
Weight (Unit and Package)	1.4 kg

# 6. Construction

## 6.1. Dimensional drawing

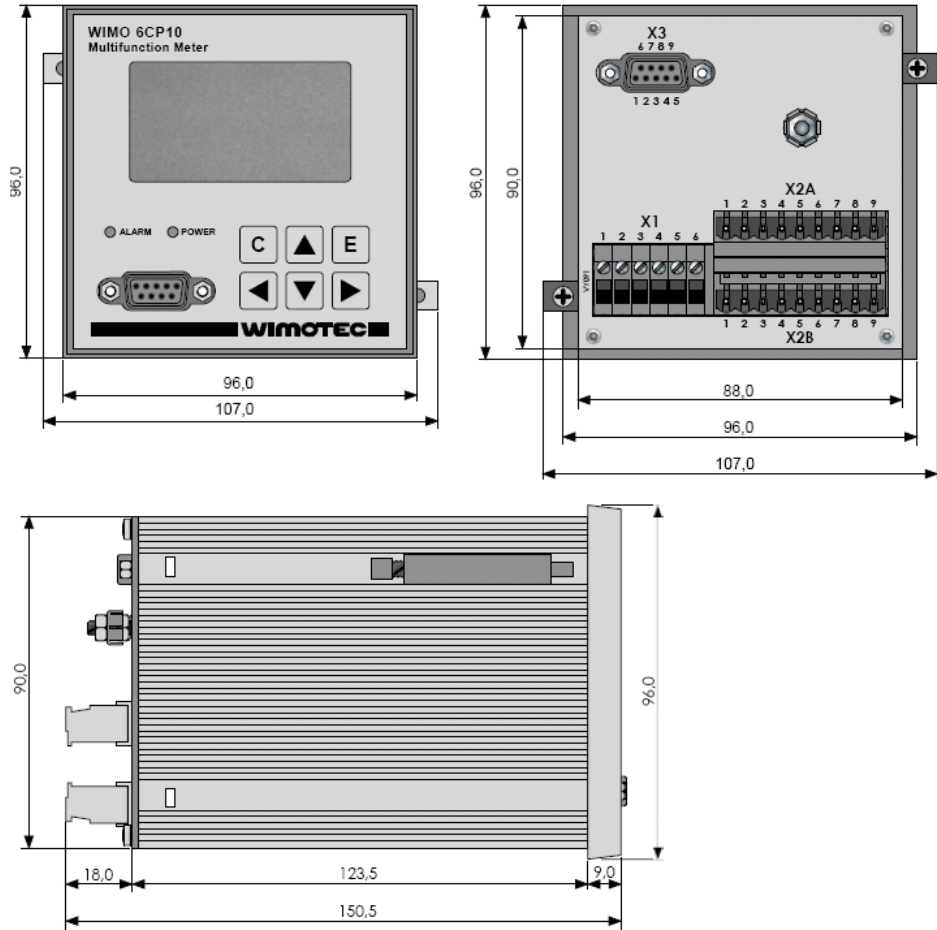

Figure 6.1-1. Dimensional drawing

# 7. Order information

When ordering, please state:

Type designation: WIMO 6CP10

Quantity :

Options ( see respective ordering code):

## 7.1. Ordering codes of WIMO 6CP10 measuring and monitoring unit

### WIMO 6CP10 ORDERING CODE

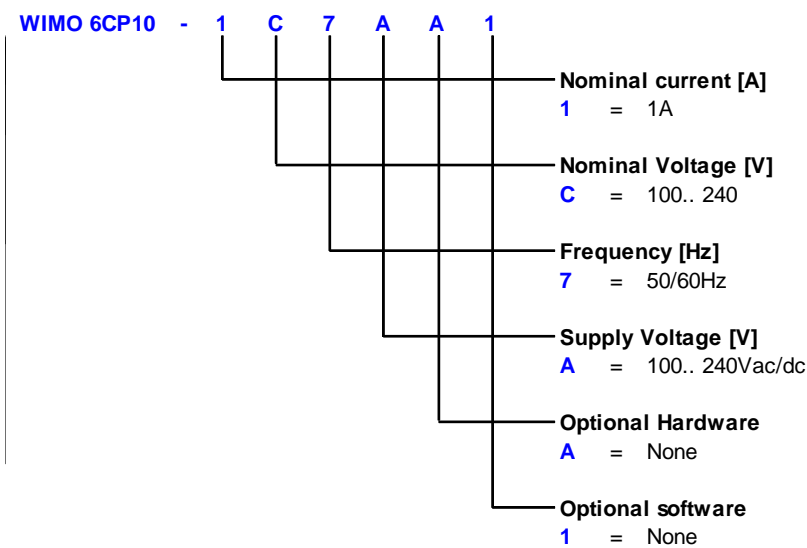

#### Accessories :

Order Code	Explanation	Note
2102-sensor	Earth-fault current sensor	Cabletrol
WIMOTEMP Pt100	Pt100 sensor	Cable length 5m
20-0604-000 sensor	Short-circuit sensor	Horstman
VEA3CGi	External ethernet interface module	
VSE001	Fiber optic Interface Module	
VSE004	RS485 Interface Module, Ext I/O interface	
VX003-3	RS232 programming cable (Vampset, VEA 3CGi)	Cable length 3m
VX030-3	Interface cable to VEA 3 CG (Ethernet module)	Cable length 3m
VX032-3	Back panel programming cable	Cable length 3m

## 8. Reference information

### Manufacturer / Service data:

Wimotec Ltd.

P.O.Box 810

FIN-65101 Vaasa, Finland

Visiting address: Yrittäjänkatu 15

Phone: +358 (0)20 753 3200

Fax: +358 (0)20 753 3205

URL: <http://www.wimotec.com>

### 24h support phone:

Tel. +358 (0)20 753 3264

Email: [support@wimotec.com](mailto:support@wimotec.com)





We reserve the right to changes without prior notice

Wimotec Ltd.

*Street address:* Yrittäjänkatu 15  
*Post address:*  
P.O.Box 810, FIN 65101 Vaasa,  
Finland

Phone: +358 20 753 3200  
Fax: +358 20 753 3205  
*Internet:* [www.wimotec.com](http://www.wimotec.com)  
*Email:* [support@wimotec.com](mailto:support@wimotec.com)

The logo consists of a thick blue horizontal bar. On the right side of this bar, the word "VAMP" is written in a bold, white, sans-serif font. The letters are slightly shadowed, giving the impression that they are floating above or attached to the bar.